



PR3210, PR3211 & PR3212 VOYAGER PRO HD ALLOY TRAY INSTRUCTIONS

FIRST TIME INSTALLATION

- Check your bar length, a minimum 1200mm bar length is required.
- Check your roof rack type, this kit suits Prorack Voyager Pro HD Alloy Trays fit Prorack HD and Tradesman roof racks out of the box, and most other popular Heavy Duty and Commercial bars with T-Slot channels.
- PR3214 Prorack Voyager Pro Tray S-Wing Adapter (sold separately) is available to fit Prorack Alloy Trays to Prorack S-Wing Through Bars 1200mm & up, and other popular curved aero bars with T-Slot channel & 1100mm of free space per bar.
- Please read instructions carefully before installation.
- Check the contents of kit. Contact your Prorack dealer if any parts appear to be missing or damaged.
- Clean your roof racks prior to fitting the Alloy Tray.
- Use caution when handling rails and slats, sharp edges may be present.
- Images throughout show a 4 slat tray indicative of PR3210 & PR3211. Note PR3212 has a 5th slat, additional Slat Clamps and associated fixing hardware.

PART

- PR3210 (fitment for two bars) 143 x 108 cm - Approx. assembly time 1hr
- PR3211 (fitment for three bars) 175 x 108 cm - Approx. assembly time 1hr 15mins
- PR3212 (fitment for three bars) 193 x 131 cm - Approx. assembly time 1hr 25mins

TOOLS REQUIRED

- 13mm Spanner
- 17mm Spanner
- Large Scissors
- Measuring Tape
- Torque Wrench (optional)
- Silicon Spray (optional)
- Screwdriver (optional)

KIT CONTENTS

Item #	Component	PR3210	PR3211	PR3212
1	Long Rail Lower Side	2	2	2
2	Long Rail Upper Side	2	2	2
3	Short Rail Lower Front & Rear (with infill)	2	2	2
4	Short Rail Upper Front & Rear (with infill)	2	2	2
5	Mounting Bracket	4	6	6
6	Mounting T-Block	4	6	6
7	Slat Clamp	6	9	12
8	Slat	4	4	5
9	Corner Moulding	4	4	4
10	Mounting Cap	4	6	6
11	Infill Lower Side	2	2	2
12	Infill Upper Side	2	2	2
13	M6 Plastite Button Socket Head Screw 20mm	16	16	16
14	M6 Spring Washer	30	33	38
15	M6 Washer	24	24	26
16	M8 Button Head Capscrew 50mm	4	6	6
17	M8 Washer 16.8 x 1.7mm	8	12	12
18	M8 Spring Washer	4	6	6
19	M8 Hex Nut	4	6	6
20	M10 Hex Screw	4	6	6
21	M10 Spring Nut	4	6	6
22	M10 Washer	4	6	6
23	M10 Spring Washer	4	6	6
24	M6 Domed Socket Head Screw	6	9	12
25	M6 Washer 18 x 1.6mm	6	9	12
26	M6 Spring Nut	6	9	12
27	M6 Button Head Capscrew 20mm	8	8	10
28	5mm Allen Key	1	1	1
29	4mm Ball End Allen Key	1	1	1

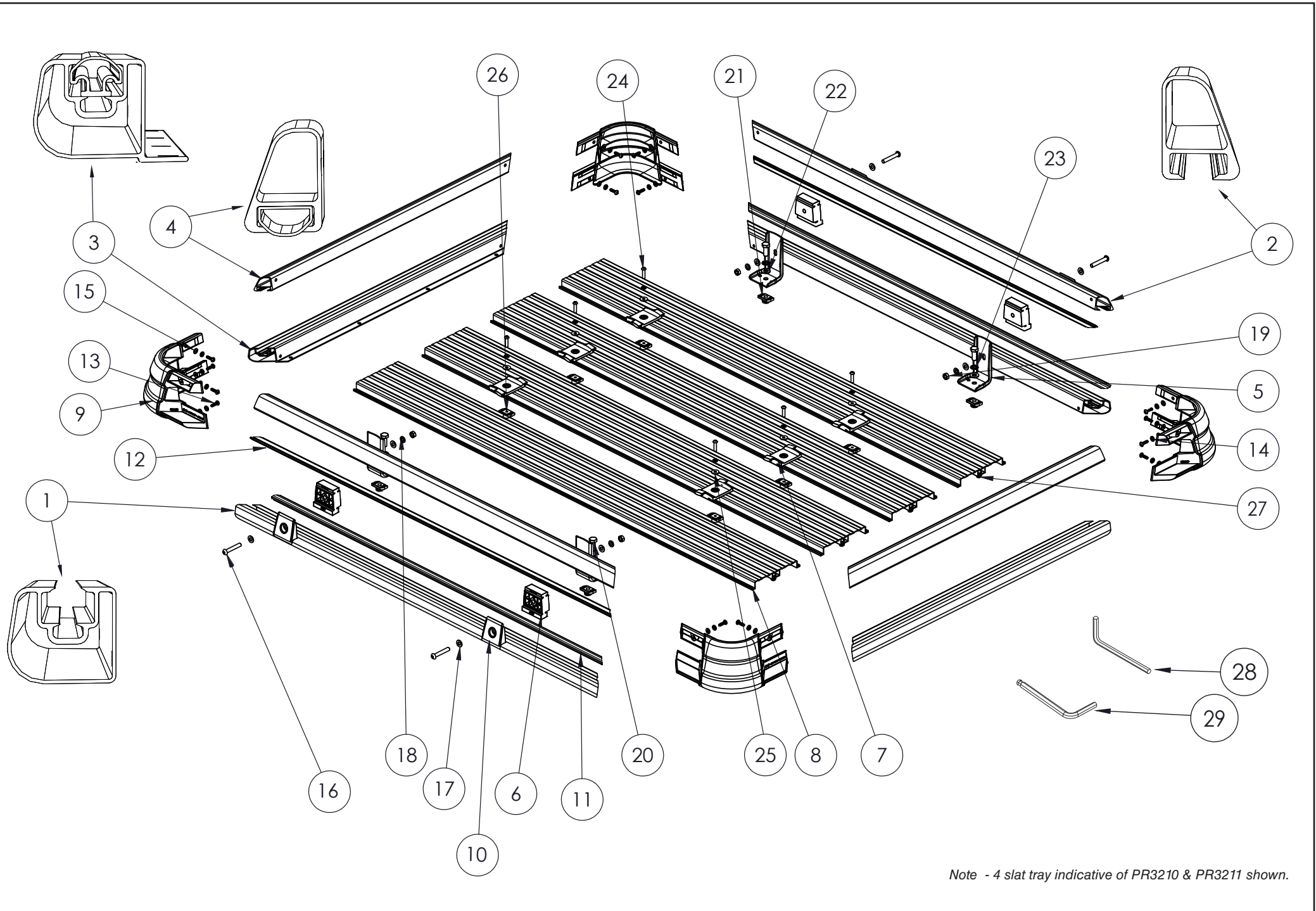

Note - 4 slat tray indicative of PR3210 & PR3211 shown.

COMPONENT SIZE GUIDE

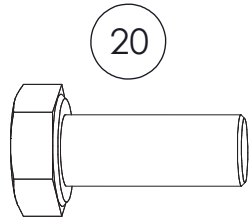

M10 Hex Screw

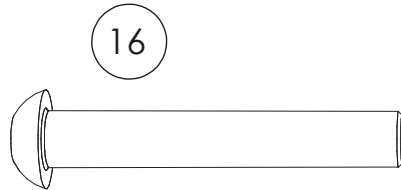

M8 Button Head Capscrew 50mm

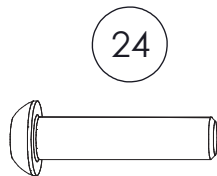

M6 Domed Socket Head Screw

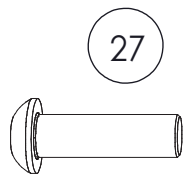

M6 Button Head Capscrew 20mm

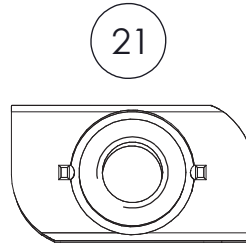

M10 Spring Nut

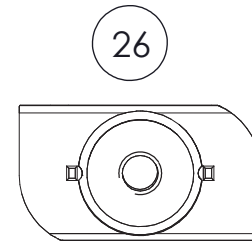

M6 Spring Nut

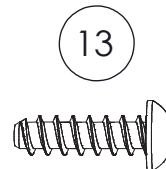

M6 Plastite Button Socket Head Screw 20mm

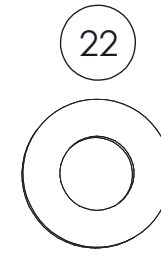

M10 Washer

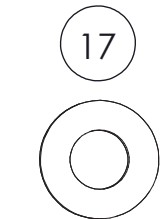

M8 Washer 16.8 x 1.7mm

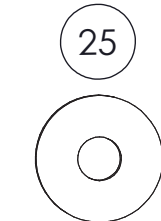

M6 Washer 18 x 1.6mm

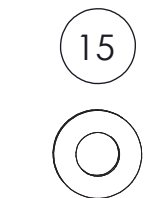

M6 Washer

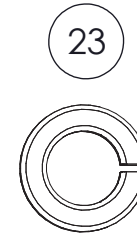

M10 Spring Washer

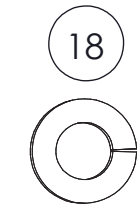

M8 Spring Washer

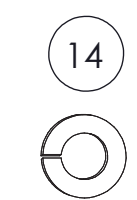

M6 Spring Washer

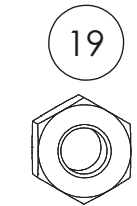

M8 Hex Nut

PLEASE USE CAUTION WHEN HANDLING RAILS AND SLATS, SHARP EDGES MAY BE PRESENT

- 1** Assemble Short Lower Rail to Corner Moulding by sliding in lower arm of Corner Moulding inside Short Lower Rail, then slide in upper arm of Corner Moulding inside Short Upper Rail. Repeat steps for other end and then the remaining Short Rails.

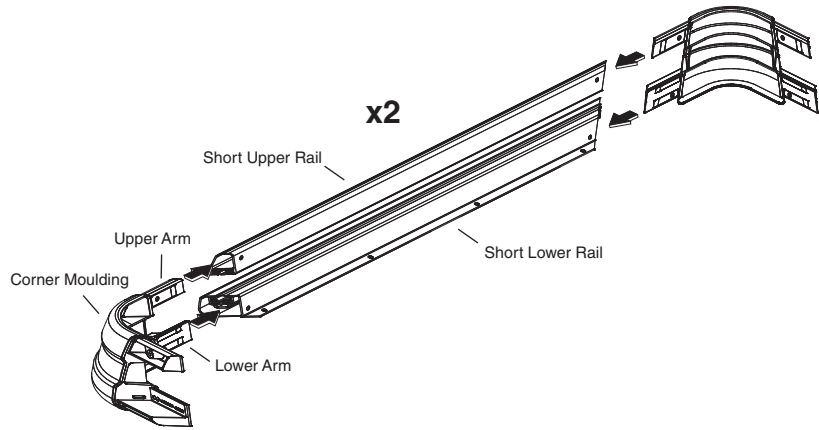

- 2** Slide Mounting T-Blocks into the channels of each Long Lower Rail. 2 x LHS & 2 x RHS for a two crossbar system, and 3 x LHS and 3 x RHS for a three crossbar system. Position Mounting T-Blocks roughly to match vehicle crossbar placement.

Note the orientation of Mounting T-Block relative to the rail profile

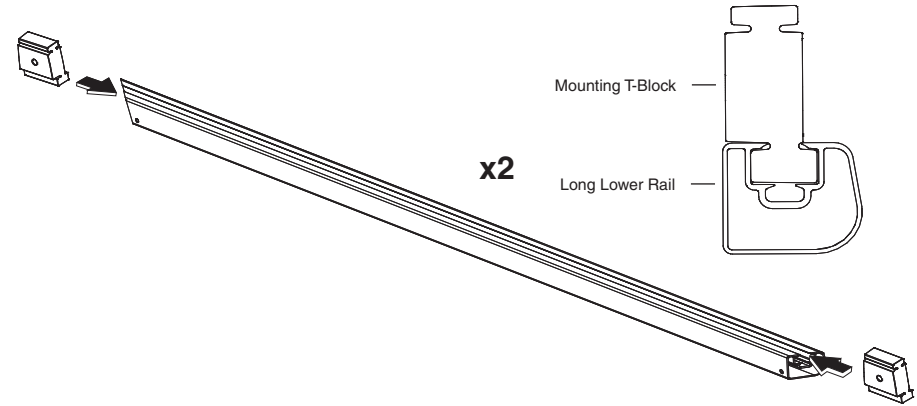

- 3** Slide Long Upper Rails on top, matching up with the grooves on the Mounting T-Blocks. Repeat step for other side.

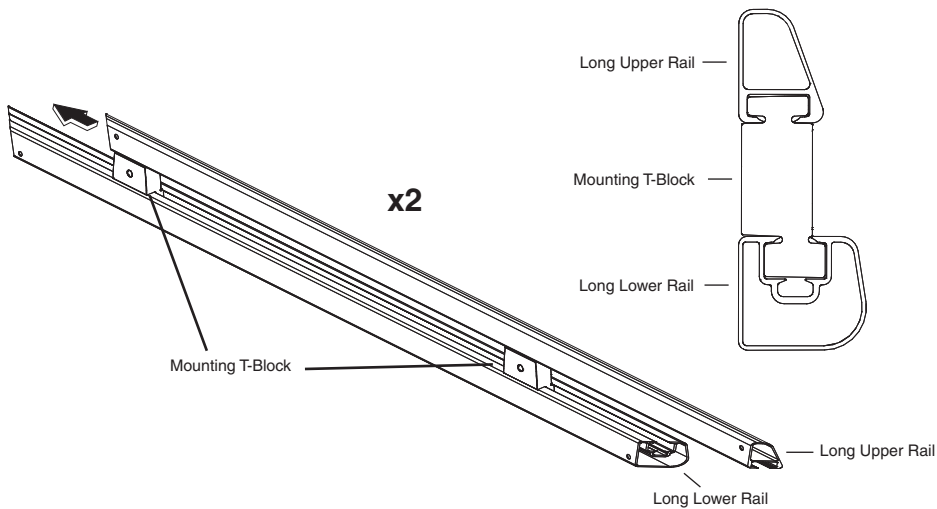

- 4** Loosely install a Mounting Bracket onto each Mounting T-Block as pictured using a Mounting Cap, 2 x M8 Washers, M8 Button Head Capscrew 50mm, M8 Spring Washer and M8 Hex Nut.

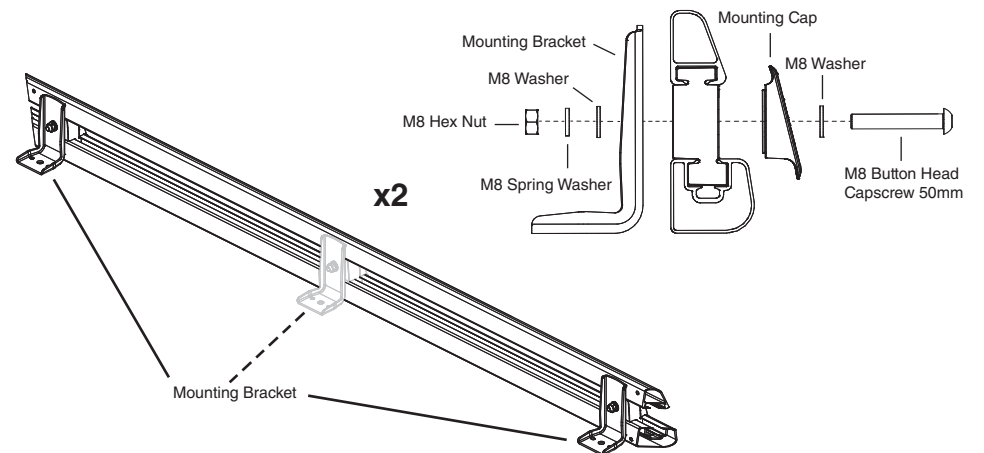

- 5** Assemble Long Lower & Upper Side rails to the 4 x Corner Moulding pieces so you have a complete frame with four sides. Secure all Upper & Lower frames to both sides of all four Corner Mouldings with M6 Washer, M6 Spring Washer and M6 Plastite Button Socket Head Screw 20mm. Tighten to 4Nm with 4mm Ball End Allen Key provided or a suitable Torque Wrench.

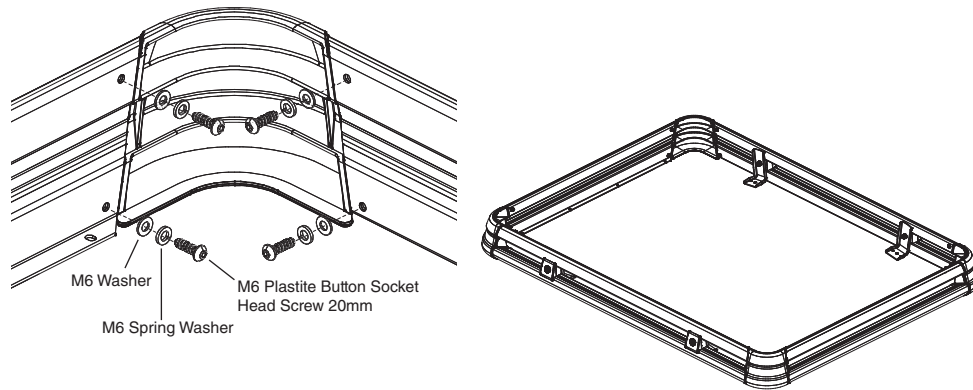

NOTE - THE IMAGES IN THIS STEP ARE SHOWN FROM UNDERNEATH THE TRAY LOOKING UP

- 6** Position Slat to line up the rivnuts in both ends with holes in the Short Lower Front & Rear Rails. Secure from underneath with M6 Washer, M6 Spring Washer and M6 Button Head Capscrew 20mm. Tighten to 6Nm with 4mm Ball End Allen Key provided or a suitable Torque Wrench. Repeat for all Slats.

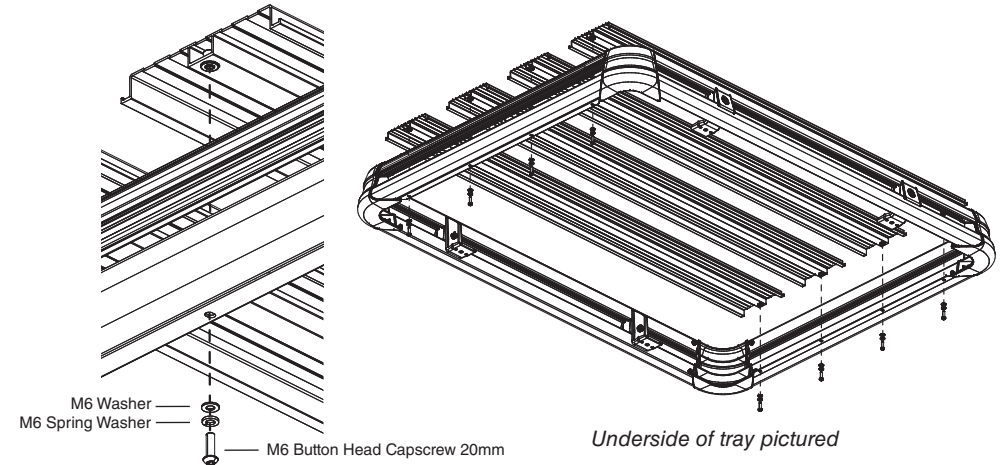

- 7** Insert 2 x M10 Spring Nuts into each crossbar 920mm apart for PR3210 / PR3211 4 slat trays and 1150mm apart for PR3212 5 slat trays, and an equal distance from the ends of each crossbar. Push Spring Nuts down into the crossbar channels and twist to lock into place as pictured.

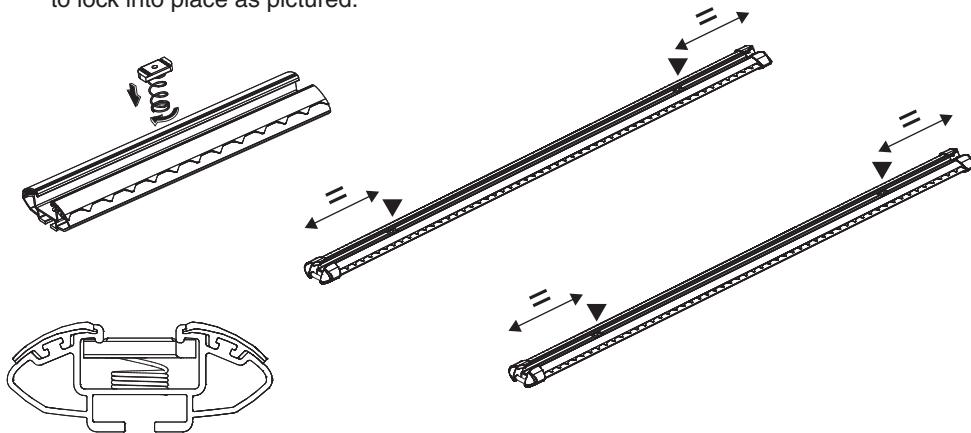

NOTE - TWO PERSON INSTALL REQUIRED FOR THIS STEP

- 8** With the help of a friend, carefully position the assembled Tray on top of vehicle crossbars. Measure the distance from each end of the crossbars to the Tray on both sides, and crossbar overhang on front and rear to ensure Tray is centrally positioned on crossbars.

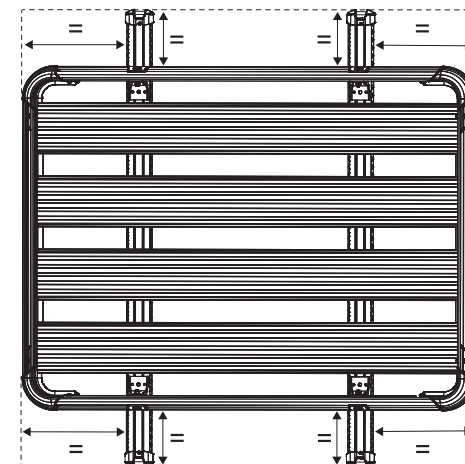

- 9** Insert 3 x M6 Spring Nuts into each crossbar channel between Slats. Push Spring Nuts down into the crossbar channels and twist to lock into place as pictured.

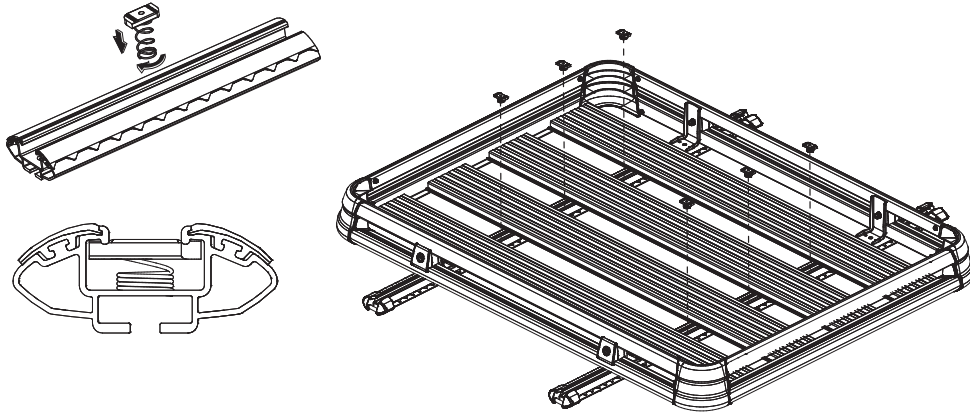

- 10** Loosely install Slat Clamps onto each M6 Spring Nut using M6 Washer 18 x 1.6mm, M6 Spring Washer and M6 Domed Socket Head Screw.

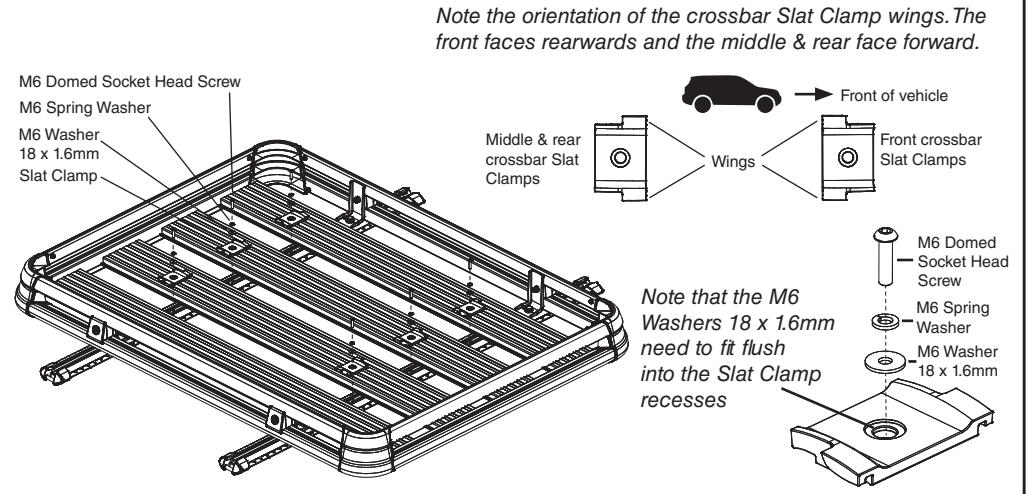

- 11** Adjust Mounting Brackets so holes align with the M10 Spring Nuts on each end of every crossbar. Secure all Mounting Brackets with M10 Washer, M10 Spring Washer and M10 Hex Screw to 25Nm using a 17mm Spanner. Tighten the M8 Button Head Cap Screws and M8 Hex Nuts that were loosely installed in Step 4 using the 5mm Allen Key provided or a suitable Torque Wrench, and a 13mm Spanner. A torque setting of 10Nm is recommended.

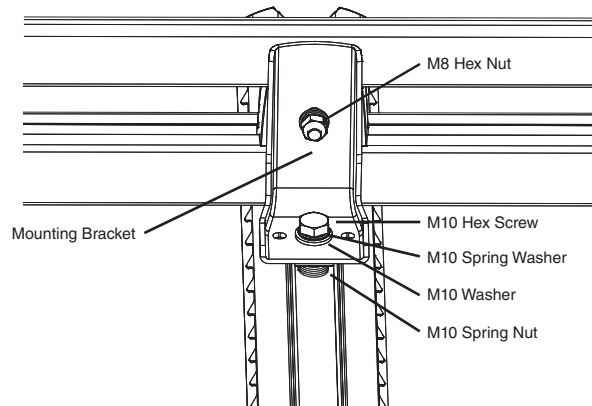

- 12** Securely tighten all Slat Clamp Screws that were loosely installed in Step 10 to 5Nm with 4mm Ball End Allen Key provided or a suitable Torque Wrench.

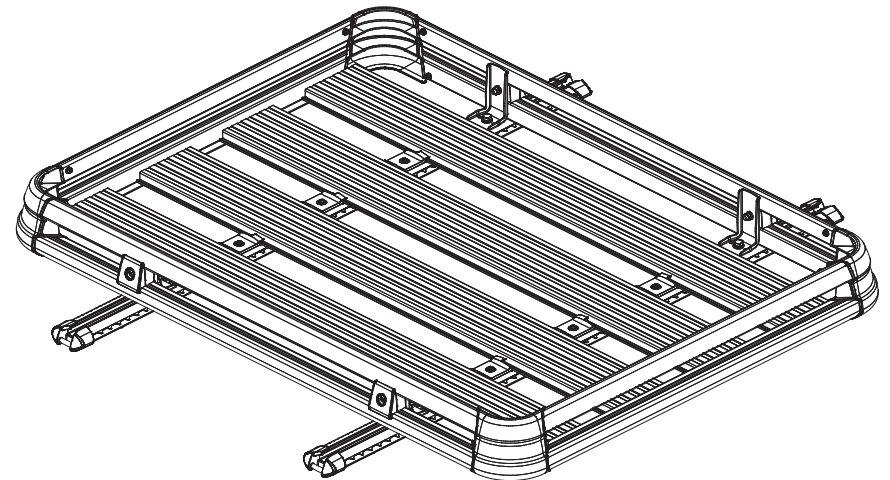

- 13** Install Rubber Infill to Upper and Lower Side Rails by measuring the spaces between Mounting T-Blocks and cutting the Rubber Infill strips to fit with a large pair of scissors. Squeeze and push cut Rubber Infill strips completely into the Upper and Lower Side Rail channels. Silicon spray can be used to assist installation.

Upper Side Rail Infill profile

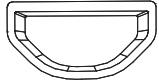

Lower Side Rail Infill profile

