

# POWERTECH

# MP3751

## 60A MPPT Solar Charge Controller



# Instruction Manual

Please read and save all instructions to ensure safe and effective use of this product.



---

## Table of Contents

<b>Preface</b>	<b>1</b>
<b>Important Safety Instructions</b>	<b>3</b>
<b>1 General Information</b>	<b>4</b>
1.1 Product overview	4
1.2 Product exterior	6
1.2.1 Appearance and ports	6
1.2.2 Indicators/Buttons/LCD	8
1.2.3 Dimensions	11
1.3 System schematic diagram	12
<b>2 Installation and Connection</b>	<b>14</b>
2.1 Precautions	14
2.2 Installation requirements	14
2.3 Wire size	16
2.4 Device connection	17
2.4.1 Connecting the ground cable (PE)	19
2.4.2 Connecting the battery	19
2.4.3 Connecting the PV modules	20
2.4.4 Connecting the accessories	21
<b>3 Operation</b>	<b>23</b>
3.1 Checking before powering on	23
3.2 Operating the device	23
3.3 Parameter setting	23
3.3.1 PV real-time data	23
3.3.2 Battery real-time data	24
3.3.3 Setting steps	24
3.3.4 Parameters list	25
3.3.5 Battery voltage control parameters	30

---

3.3.6 Control strategy under lithium battery protocol	34
3.3.7 Setting parameters remotely	36
<b>4 Maintenance</b>	<b>38</b>
<b>5 Protections</b>	<b>39</b>
<b>6 Troubleshooting</b>	<b>41</b>
<b>7 Technical Specifications</b>	<b>45</b>
<b>8 Appendix Abbreviation Index</b>	<b>49</b>
<b>9 Warranty Information</b>	<b>52</b>

---

## Preface

### Disclaimers

Before using the product, please read this manual carefully to ensure you fully understand the product and can use it correctly. Please keep this manual properly for future reference after reading. Improper use of this product may cause serious injury to you or others, or result in product damage and property loss. By using this product, you are deemed to have understood, acknowledged, and accepted all terms and contents in this manual. Electus Distribution shall not be liable for any losses caused by the user's failure to use the product in accordance with this manual.

#### **The warranty does not apply to the following conditions:**

- Damage caused by improper use or inappropriate environments (such as the humid, salt spray, corrosive, greasy, flammable, explosive, dust accumulative or other harsh environments).
- The actual current/voltage/power exceeds the limit value of the controller.
- Damage caused by operating temperature exceeding the rated temperature range.
- Electric arc, fire, explosion and other accidents caused by failure to follow controller labels or manual instructions.
- Unauthorized disassembly and maintenance of the controller.
- Damage caused by force majeure such as lightning strikes, rainstorms, mountain torrents and utility failures.
- Damage occurred during transportation or loading/unloading the controller.

---

## Scope of application

This user manual describes the installation, electrical connection, commissioning, maintenance and troubleshooting of the MP3751 solar charge controller (hereinafter referred to as "controller").

This manual is only intended for professionals who are familiar with local regulations, standards and electrical systems, have received professional training, and know the product well.

## Symbol definition

To ensure the user's personal and property safety during operation, as well as the efficient use of this product, relevant safety instructions are provided in the manual and highlighted with the corresponding symbols. To prevent personal injury and property damage, please fully understand and strictly follow these highlighted information. The symbols used in this manual are as follows:



Indicates a high-level hazard that, if not avoided, will result in serious injury or death.



Indicates a medium-level hazard that, if not avoided, could result in death or serious injury.



Indicates a low-level hazard that, if not avoided, could result in minor or moderate injury.

### NOTICE

Indicates an important reminder during the operation which, if ignored, may result in an equipment error alarm.

---

### Tip

Indicates recommendation for reference.

---



Read through the user manual before any operations.

---

---

## Important Safety Instructions

**Please keep this manual for future reference.**

- Read all the instructions and warnings carefully in the manual before installation.
- No user-serviceable components inside the controller, do not attempt to disassemble or repair the controller.
- Install the controller indoors to avoid component exposure and water ingress.
- Install the controller in a well-ventilated place, the heat sink temperature will be very high during operation.
- Do not install the controller in the humid, salt spray, corrosive, greasy, flammable, explosive, dust accumulative or other harsh environments.
- It is recommended to install the proper fast-acting fuses/breakers externally.
- Disconnect PV array connections and the battery fast-acting fuse/breakers before controller installation and adjustment.
- Check whether the wiring is tight to avoid the danger caused by heat accumulation due to loose connection.
- The entire system should be installed and operated by professional personnel.

---

# 1 General Information

## 1.1 Product overview

MP3751 adapts the brand new generation of MPPT control algorithm to improve the tracking and response speed of maximum power point. Minimizing the loss rate and time of the maximum power point guarantees the maximum power point tracking efficiency, response speed and DC/DC conversion efficiency in high and low power bands. It can track the maximum power point of the PV arrays in various sunlight conditions and capture the energy from the solar panels.

The controller adopts a two-compartment structure separating the electronic components (upper chamber) from the cooling system (lower chamber). The isolated airflow design ensures efficient heat dissipation and superior dust protection, significantly improving reliability, adaptability, and operational lifespan.

It supports no-battery mode operation by allowing the load to be connected directly to the battery terminals on the controller, and is fully compatible with major lithium battery types.

Excellent low-power design that significantly reduces static power consumption and extends system standby time.

With the functions such as the charging current limit, charging power limit and automatic reduction of charging power at high temperature, it can ensure the system stability when it is connected to the excess PV modules and operating at high temperature.

The controller has short-circuit protection and isolated RS485 communication interface that can be connected with optional WiFi, Bluetooth, TCP, 4G and other modules to achieve remote monitoring. The communication port can be set to enable or disable according to actual needs, and the static power consumption can be further reduced when the communication port is disabled.

Self-adaptive three-stage charging mode can effectively extend the service life of battery and significantly improve the system performance. It also has comprehensive electronic protections for overcharge, over-discharge and PV reverse polarity etc., to ensure the safety, stability and long-lasting operation of the solar system. It supports up to 6 controllers for parallel charging, which is convenient for system capacity expansion and suitable for different power needs. The controller can be widely used for RV, ship, multiple industrial monitoring systems, small and medium-sized solar power supply systems and other fields.

### Features

- Low power consumption with static loss less than 50mA
- No-battery mode operation
- Advanced MPPT technology, with maximum tracking efficiency not less than 99.5%
- Supporting two PV inputs to improve PV utilization<sup>(1)</sup>
- Two-compartment design for superior dust resistance

- 
- Conversion efficiency up to 98.5%
  - Supporting multiple battery types, including lithium batteries
  - Stable self-activation for lithium batteries
  - Supporting local setting of main control parameters
  - RS485 communication interface, connected with optional WiFi, Bluetooth, TCP, 4G and other modules for remote monitoring
  - Dual limits for rated charging power and charging current
  - Automatic power reduction when charging at high temperature
  - Comprehensive electronic protections
  - Rated IP20 protection level
  - Built-in BMS communication port
  - Built-in CAN parallel communication port
  - Real-time data logging, event logging and energy statistics
  - Compliant with IEC62109, EMC and other relevant standards

## 1.2 Product exterior

### 1.2.1 Appearance and ports

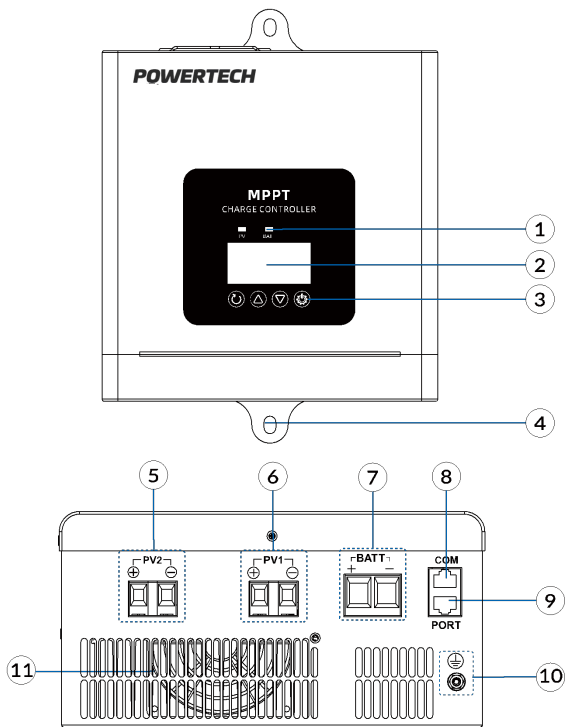

No.	Description	No.	Description
1	Indicator	7	Battery terminals <sup>(1)</sup>
2	LCD	8	COM port (RJ45, with isolation design, 5VDC/200mA) <sup>(2)</sup>
3	Buttons	9	BMS/RTS/CAN COM interface <sup>(3)</sup>
4	Mounting hole*2	10	Grounding terminal
5	PV2 terminals <sup>(1)</sup>	11	Cooling fan
6	PV1 terminals <sup>(1)</sup>		

- (1) The controller is of common negative design, where the negative terminals of PV array and battery are the same negative grounding terminals.
- (2) RS485 communication interface. It utilizes the MODBUS protocol and can be connected to various modules – including computer cloud platforms, WiFi, Bluetooth, TCP, and 4G – to enable remote monitoring. The pins of the RS485 interface (RJ45) are defined as follows:

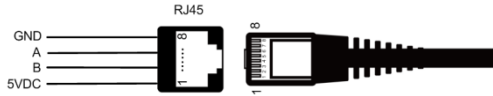

Pin	Definition	Pin	Definition
1	+5VDC	/	/
/	/	6	RS485-A
3	RS485-B	/	/
/	/	8	GND

(3) Multi-function multiplexed port:

- When the system uses lithium batteries with BMS function, connect the BMS-Link module and lithium batteries through the **port 9**; with the setting of the BMS protocol number, the BMS-Link module can convert the BMS protocols of different lithium battery manufacturers into our standard protocols to realize the communication between the controller and lithium batteries BMS of different manufacturers. When using the Pylon batteries with BMS protocol number of 21, and the Powertech batteries with BMS protocol number of 10, 27 or 34, you can connect the batteries directly to **port 9** by removing the BMS-Link module, and set the BMS protocol number accordingly for BMS communication. Pylon lithium battery communication cable (CC-RJ45-RJ45-PYLON-200)(3, 6) or Powertech lithium battery communication cable (CC-RJ45-RJ45-150)(3, 6) is required for this operation.

---

**Tip** Please go to [POWERTECH](http://POWERTECH) official website to check or download the currently supported BMS manufacturers and the BMS parameters.

---

- When the system has no BMS function, it is required to set the “BPRO (BMS protocol number)” as 32, connect a remote temperature sensor (model: RTS-D47K) through **port 9** to detect the battery temperature, sampling distance ≤ 20 meters. **Note:** If the remote temperature sensor is not connected to the controller, the default temperature for battery charging is 25°C without temperature compensation.

- The CAN communication is used for multiple controllers parallel connection, and shares **port 9** with the BMS interface . The pin definitions are as follows:

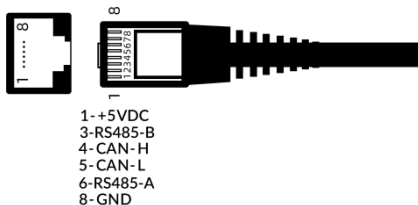

Pin	Definition	Pin	Definition
1	+5VDC	5	CAN-L
2	/	6	RS485-A
3	RS485-B	7	/
4	CAN-H	8	GND

### 1.2.2 Indicators/Buttons/LCD

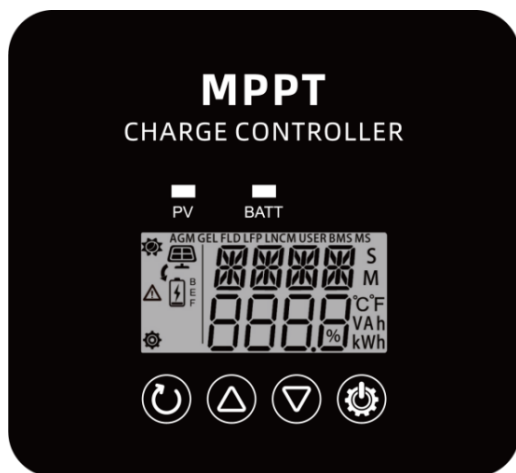



#### Tip

The LCD can be viewed clearly when the angle between the end-user's horizontal sight and the LCD is within 90°. If the angle exceeds 90°, the information on the LCD cannot be viewed clearly.

a) Indicator

Indicator	Color	Status	Description
PV	Green	Solid ON	PV voltage is higher than turn-off voltage, but no charging.
	Green	Solid OFF	1. No sunlight; 2. Connection error; 3. PV low voltage
	Green	Slowly flashing (1Hz)	Charging normally
	Green	Fast flashing (4Hz)	PV input overvoltage, PV mode error, PV input reverse connection, PV power too low
BATT	Green	Solid ON	Battery is normal.
	Green	Slowly flashing (1Hz)	Battery fully charged, SOC low battery alarm
	Green	Fast flashing (4Hz)	Battery overvoltage, cell overvoltage
	Orange	Solid ON	Battery Undervoltage (including battery pack under voltage), cell under voltage
	Red	Solid ON	Battery over discharging
	Red	Slowly flashing (1Hz)	Battery over temperature, battery low temperature, cell over temperature, cell low temperature, BMS charging protection, BMS discharging protection
	Red	Fast flashing (4Hz)	BMS other faults, BMS sensor fault, lithium battery rated voltage identification error alarm
PV (fast flashing green) & BATT (fast flashing orange)			Equipment over temperature, DSP communication failure



## b) Buttons

Buttons	Operation	Description
	Press the button (< 50ms)	Exit the current interface.
	Press the button (< 50ms)	<ul style="list-style-type: none"> <li>• Browse the interface: Up/Down</li> <li>• Set the browsing interface: Up/Down</li> <li>• Parameters setting interface: Increase or decrease the parameter value as per step size.</li> </ul>
	Press and hold the button (> 2.5s)	<ul style="list-style-type: none"> <li>• Browse the interface: invalid.</li> <li>• Set the browsing interface: invalid.</li> <li>• Parameters setting interface: Increase or decrease the parameter value quickly as per step size.</li> </ul>
	Press the button (< 50ms)	Confirm the setting parameters.
	Press and hold the button (> 2.5s)	<ul style="list-style-type: none"> <li>• Switch the real-time interface to setting browsing interface.</li> <li>• Switch the setting browsing interface to parameter settings interface.</li> <li>• Confirm the setting parameters.</li> </ul>

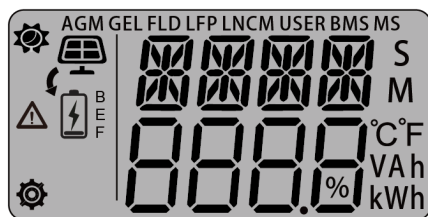
## c) LCD



Name	Icon	Status
PV array		Day

		Night
		Not charging
		Charging <b>Note:</b> "B, E, F" refer to bulk charging, equalization charging and float charging respectively.
	PV1/PV2	Displays the input voltage, input current, input power and input energy of PV1 and PV2, see Subsection <a href="#">3.3.1 PV real-time data</a> .
Battery	BAT	Displays battery voltage, battery charging current, battery charging power, battery SOC, and battery temperature, see Subsection <a href="#">3.3.2 Battery real-time data</a> .

### 1.2.3 Dimensions

(Unit: mm)

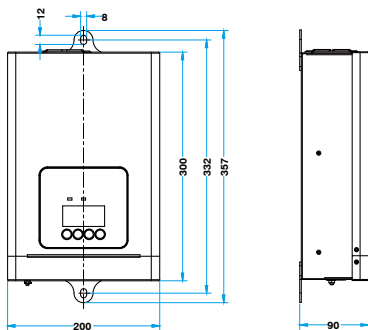

### 1.3 System schematic diagram

**Tip** The schematic diagram below shows the PV independent mode as an example. For PV parallel mode, refer to the wiring diagram “PV Parallel Input” in Section 2.4 Device connection.

#### • No-battery mode

When there is no battery, MP3751 controller can be connected to the inverter directly. The inverter must be connected to the battery terminals of the controller and meet the following conditions at the same time:

- 1) When connecting a high-frequency inverter: PV input power > (Load output power divided by Inverter conversion efficiency divided by Controller conversion efficiency).
- 2) When connecting an industrial frequency inverter: PV input power > (Load output power divided by Inverter conversion efficiency divided by Controller conversion efficiency) × 2.

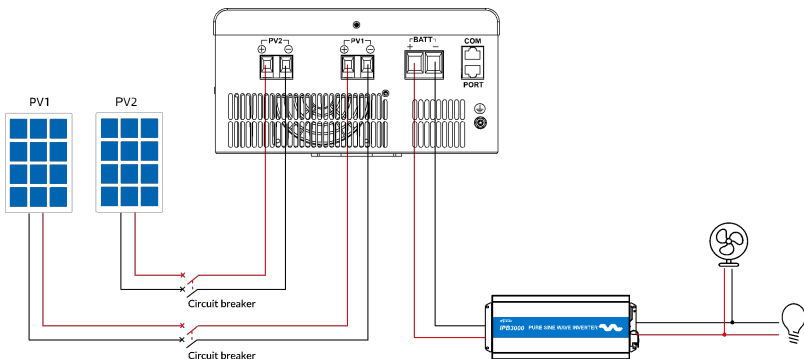

#### NOTICE

When operating in No-battery mode, ensure the connected load's input voltage range exceeds the system's rated voltage at the BATT terminals.

- **Battery mode**

In a system with battery connected, if you need to connect an inverter, please connect the inverter directly to the battery pack.

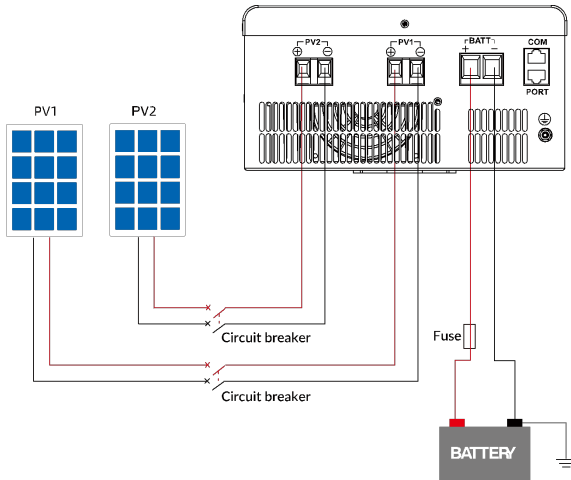

#### NOTICE

- Ensure that the length of battery connection cable is less than 3 meters.
- Ensure that the length of communication cable is less than 3 meters.
- It is recommended that the length of the PV connection cable is less than 3 meters. If the length of the PV connection cable is less than 3 meters, it meets the requirements of EN/IEC61000-6-4 standard; If the length of the PV connection cable exceeds 3 meters, it may not meet the requirements of the EN/IEC61000-6-4 standard.

---

## 2 Installation and Connection

### 2.1 Precautions

- Be careful when installing the batteries. Wear protective goggles when installing flooded lead-acid batteries, and rinse with clean water in time once in contact with battery acid.
- The battery and PV connections must be guarded against with inadvertent contact. Install the solar charge controller in an enclosure.
- Keep the battery away from any metal objects to prevent battery short circuit.
- Acidic gases may be generated when charging the battery, ensure that the environment is well ventilated.
- Avoid direct sunlight and rain infiltration for outdoor installation.
- Do not install the controller in the humid, salt spray, corrosive, greasy, flammable, explosive, dust accumulative or other harsh environments.
- Loose power connections and corroded cables may result in high heat, melting cables insulation, burning surrounding materials, or even causing a fire. Ensure tight connections and secure cables with cable ties to prevent them from swaying while moving the controller.
- Charge the lead-acid and lithium-ion batteries that are within the control range of this controller only.
- The battery terminals on the controller can be connected to either the same battery or a group of batteries. The following instructions in the manual are for use with a single battery, but they are also applicable to a system with a group of batteries.
- Select the system connection cables according to the current density of no greater than  $5A/mm^2$ .
- The stripped length for wiring should not be too long, and the exposed metal part of the wire should not protrude from the metal part of the terminal block.
- Please refer to IEC62109 for the cross-sectional area of the grounding wire, which should not be less than  $4mm^2$ .
- The torque for tightening the wiring screws should be not less than  $1.2 N\cdot m$ .

### 2.2 Installation requirements

#### NOTICE

When installing the controller, ensure that there is enough air flow through the controller's heat sink, and leave at least 150mm of clearance above and below the controller to guarantee natural convection for heat dissipation. If the controller is mounted in a closed cabinet, ensure that heat can be dissipated through the cabinet.

---

**Step 1: Determine the installation position and heat-dissipation space**

When installing the controller, ensure that there is enough air flow through the controller's heat sink, and leave at least 150mm of clearance above and below the controller to guarantee natural convection for heat dissipation.

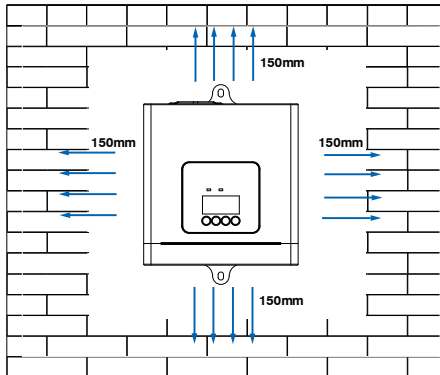
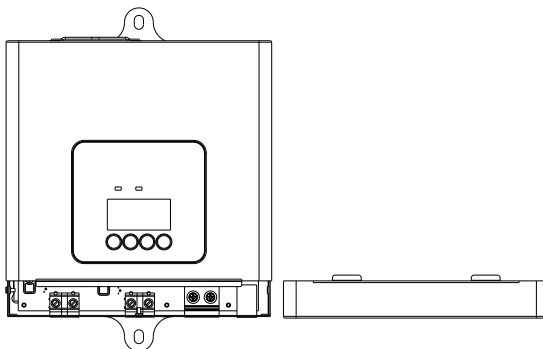
**Step 2: Remove the terminal cover with a screwdriver before wiring.****Serial connection (string) of PV modules**

Due to the different types of PV modules on the market, and as an important part of the PV system, it is essential for the controller to suit various types of PV modules and to maximize the conversion of solar energy into electricity. According to the open-circuit voltage ( $V_{OC}$ ) and the maximum power point voltage ( $V_{MPP}$ ) of the MPPT controller, the suitable serial connection for different PV modules can be calculated. The following PV module series connection table is for reference only.

## MP3751:

Battery Voltage/ PV Specifications	36-cell Voc < 23V		48-cell Voc < 31V		54-cell Voc < 34V		60-cell Voc < 38V	
	Max.	Best	Max.	Best	Max.	Best	Max.	Best
12V	4	2	3	2	2	2	2	2
24V	6	3	4	4	2	4	2	3
48V	6	5	5	4	3	4	3	3

Battery Voltage/ PV Specifications	72-cell Voc < 46V		96-cell Voc < 62V		Thin-film module Voc > 80V
	Max.	Best	Max.	Best	
12V	2	1	1	1	1
24V	3	2	2	1	1
48V	3	2	2	2	1

**Note:** The above parameters are calculated under the STC (Standard Test Condition)—temperature at 25°C, air mass 1.5, irradiance 1,000W/m<sup>2</sup>.

## 2.3 Wire size

The wiring and installation methods must conform to the national and local electrical code requirements.

### ● Recommended PV array wire size

Since the PV array output current varies according to the PV module's type, connection method and sunlight angle, the minimum PV cable specifications can be calculated by the PV  $I_{sc}$  (short circuit current). For details, please refer to the short-circuit current value in the PV module specifications sheet (the short-circuit current remains unchanged when PV modules are connected in series; when connected in parallel, the short-circuit current is the sum of the short-circuit currents of the parallel modules). The PV array's ISC must not exceed the controller's maximum PV input current. For controller's maximum PV input current and maximum PV cable specifications, please refer to the table below.

Model	Maximum Input Current	Maximum Wire Size
MP3751	60A	16mm <sup>2</sup> /6AWG

## NOTICE

- When the PV modules connect in series at the lowest temperature, the total voltage must not exceed the controller's maximum PV open circuit voltage 150V(TEP\*\*15).
- When the PV modules connect in series at 25°C, the total voltage must not exceed the controller's maximum PV open circuit voltage 135V (TEP\*\*15).
- When the PV modules connect in series at the lowest temperature, the total voltage must not exceed the controller's maximum PV open circuit voltage 250V(TEP\*\*25).
- When the PV modules connect in series at 25°C, the total voltage must not exceed the controller's maximum PV open circuit voltage 225V (TEP\*\*25).

### ● Recommended battery wire size

Battery wire size should be selected according rated current, please refer to the table below for wiring specifications.

Model	Rated Charging Current	Maximum Wire Size
MP3751	60A	16mm <sup>2</sup> /6AWG

## NOTICE

- The wire size is only for reference. If there is a long distance between the PV array and the controller or between the controller and the battery, thicker cables can be used to reduce the voltage drop and improve system performance.
- For the battery, the recommended wire size is selected according to the conditions that its terminals are not connected to any additional inverter.

## 2.4 Device connection



### DANGER

- Risk of explosion! Never install the controller in the enclosed space with flooded batteries! Do not install it in a confined area where battery gas can accumulate either.
- Electric shock hazard! The PV array may generate a very high open circuit voltage. Disconnect the circuit breaker or fast-acting fuse first and be careful when wiring.

Connect the controller in the sequence of "① Ground > ② Battery > ③ PV array > ④ Optional accessories", and disconnect the controller wiring in the reverse order of the following diagram.

- PV Independent Input

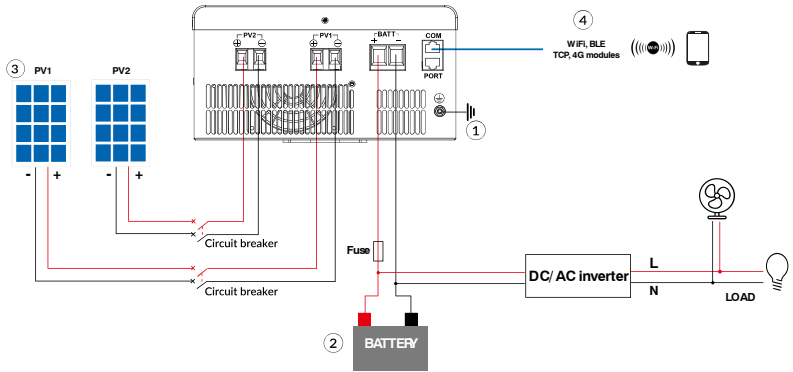

- PV Parallel Input

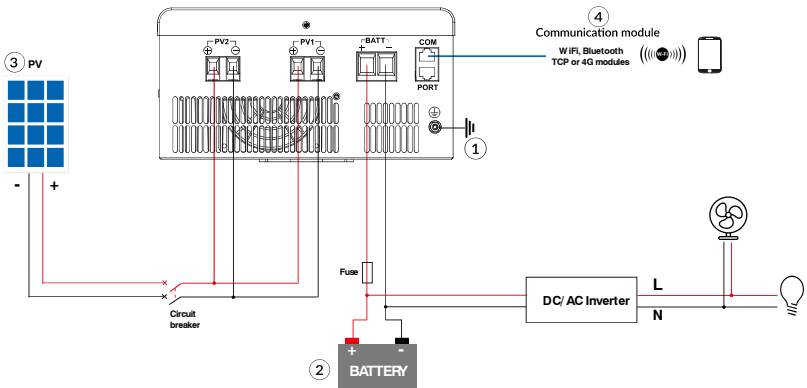

In addition to supporting stand-alone applications, the MP3751 also support the parallel operation of multiple controllers of the same model (up to 6 units). The wiring diagram of multiple controllers is as follows. For instructions on parallel wiring of multiple controllers, please refer to the manual "Solar Charge Controller Parallel Operation Guide".

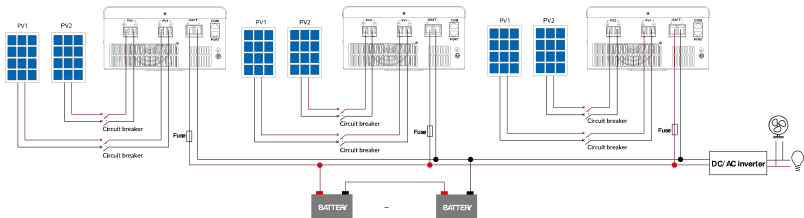

## 2.4.1 Connecting the ground cable (PE)

MP3751 is a common negative controller. Negative terminals of the PV array and battery can be grounded simultaneously, or any negative terminal is grounded.

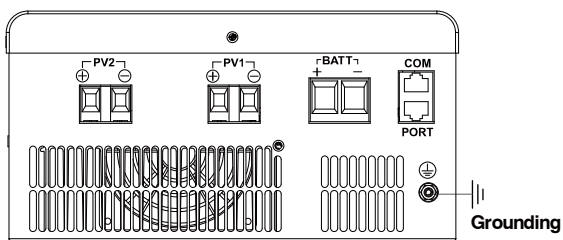

### **⚠ DANGER**

According to the actual application, the negative terminals of the PV array, battery may not be grounded. However, the grounding terminal on the shell must be grounded to effectively shield the external electromagnetic interference and to avoid the electric shock to the human body caused by the live shell.

### NOTICE

For common-negative systems, such as the RV system, it is recommended to use a common-negative controller. If a common-positive controller is used and the positive electrode is grounded in the common-negative system, the controller may be damaged.

## 2.4.2 Connecting the battery

### NOTICE

- Do not connect the circuit breaker or fast-acting fuse when wiring and ensure that the leads of "+" and "-" poles are connected correctly.
- A fast-acting fuse whose current is 1.25 to 2 times the controller's rated current must be installed on the battery side with a distance from the battery no longer than 150mm.

- Please connect the inverter directly to the battery when connecting inverter in the system.

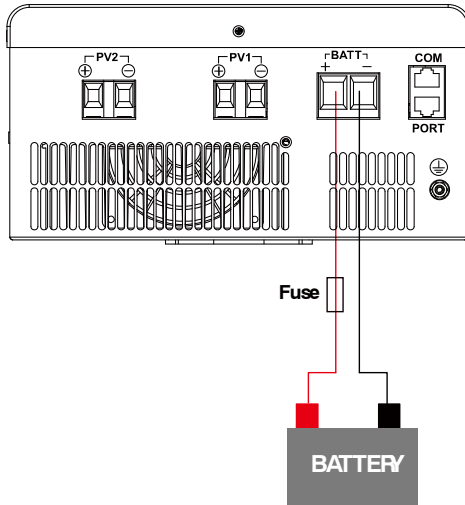

### 2.4.3 Connecting the PV modules

#### **⚠ DANGER**

Electric shock hazard! The PV array can generate very high voltage, disconnect the circuit breaker before wiring, and ensure that the leads of "+" and "-" poles are connected correctly.

#### **NOTICE**

If controller is used in an area with frequent lightning strikes, an external surge arrester must be installed at the PV input and utility input terminals.

#### **Tip**

The schematic diagram below shows the PV independent mode as an example. For PV parallel mode, refer to the wiring diagram "PV Parallel Input" in Section [2.4 Device connection](#).

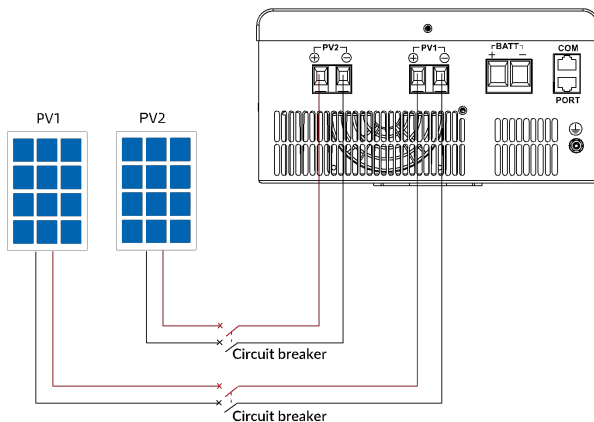

## 2.4.4 Connecting the accessories

### a) Connect the BMS-Link module

When the system uses lithium batteries with BMS function, connect the BMS-Link module and lithium batteries through the port 9; with the setting of the BMS protocol number (BPRO, UBS), the BMS-Link module can convert the BMS protocols of different lithium battery manufacturers into our standard protocols to realize the communication between the controller and lithium batteries BMS of different manufacturers.

**Note:** The controller will connect automatically if the correct protocol number is set.

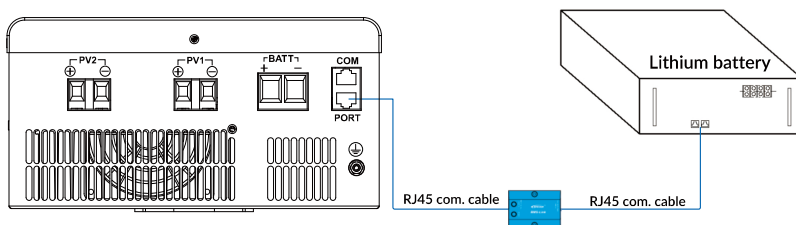

### b) Connect the remote temperature sensor (model: RTS-D47K)

When the battery has no BMS function, attach RTS-D47K close to the battery to detect the battery temperature in real time, and the temperature data will be transmitted to the controller via RS485 communication to improve system safety.

**Note:** It is required to set the BMS protocol number as 32 when connecting the remote temperature sensor to BMS port.

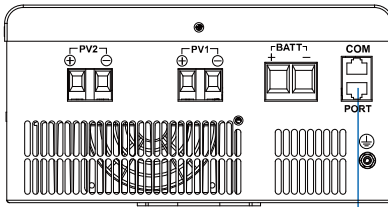

RS485 com. cable



Remote temperature sensor

Fixed by high temperature double coated tap

**Note:** If the remote temperature sensor is not connected to the controller, the default temperature for battery charging is 25°C without temperature compensation.

### c) Connect the communication module

Connect the communication modules such as WiFi, Bluetooth, TCP or 4G modules to the RS485 COM port. You can remotely monitor the controller or modify its related parameters on the APP by phone. For specific setting methods, please refer to the user manuals of communication modules such as Cloud APP, WiFi, Bluetooth, TCP and 4G (4G module needs to be powered separately).



Communication module

WiFi, Bluetooth  
TCP or 4G modules

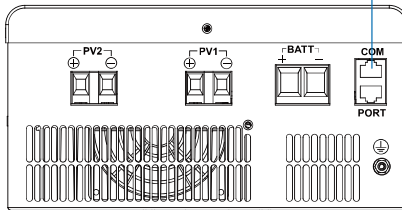

## 3 Operation

### 3.1 Checking before powering on

- Whether the controller is installed correctly and securely.
- Whether the terminal wirings are connected correctly.
- Whether the terminal polarities are connected correctly.
- Whether the communication module is connected correctly and securely.

### 3.2 Operating the device



Connect the battery's fast-acting fuse to power on the controller. After the LCD normally displays, connect the PV array's circuit breaker. The charging indicator is flashing slowly during PV charging.

#### Tip

If the controller does not work properly or the fault indicator indicates after the controller is powered on, refer to Chapter 6 [Troubleshooting](#).

### 3.3 Parameter setting

#### 3.3.1 PV real-time data

After the controller is powered on and works normally, press   on the LCD initial interface to display the following PV real-time data interfaces in sequence, you can view PV1 input voltage, PV1 input current, PV1 input power, PV1 input energy, PV2 input voltage, PV2 input current, PV2 input power, and PV2 input energy. **Note:** Model with single PV input displays PV1 only.

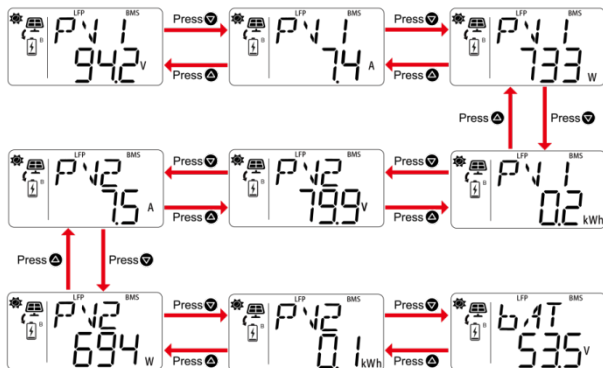



### 3.3.4 Parameters list

The default values and setting range of the controller parameters on the LCD are shown in the following table; except for some read-only parameters, other parameters can be modified by the PC or APP:

No.	Parameters	Default	User define
1	BT (Battery Type)	AGM	<b>48V system:</b> AGM, GEL, FLD, LFP15S, LFP16S, NCM13S, NCM14S, USER
			<b>24V system:</b> AGM, GEL, FLD, LFP8S, NCM6S, NCM7S, USER
			<b>12V system:</b> AGM, GEL, FLD, LFP4S, NCM3S, USER
2	BC (Battery Capacity)	100Ah	User define: 1-4,000Ah Products of 200Ah and below, small step size 1Ah, large step size: 10Ah. Products above 200Ah, small step size 5Ah, large step size: 50Ah <b>Note:</b> To accurately display the battery capacity, you need to set this parameter according to the actual battery capacity.
3	RVL (Rated Voltage Level)	12.0V	User define: 12.0V (auto-recognition), 12V, 24V, 36V, 48V <b>Note:</b> For non-lithium batteries, select the voltage level directly and restart the controller for the settings to take effect; for lithium batteries, switch the battery type to "USER" first, then adjust the voltage level, select the corresponding lithium battery type, and restart to activate the settings.
4★	OVD (Overvoltage Disconnect Voltage)	16.0V (12V system)	User define: 9.0-17.0V, small step size: 0.1V, large step size: 1V
		32.0V (24V system)	User define: 18.0-34.0V, small step size: 0.1V, large step size: 1V
		64.0V	User define: 36.0-68.0V, small step

		(48V system)	size: 0.1V, large step size: 1V
5★	OVR (Overvoltage Recovery Voltage)	15.0V (12V system)	User define: 9.0–15.5V, small step size: 0.1V, large step size: 1V
		30.0V (24V system)	User define: 18.0–31.0V, small step size: 0.1V, large step size: 1V
		60.0V (48V system)	User define: 36.0–62.0V, small step size: 0.1V, large step size: 1V
6★	ECV (Equalization Charging Voltage)	14.6V (12V system)	User define: 9.0–15.5V, small step size: 0.1V, large step size: 1V
		29.2V (24V system)	User define: 18.0–31.0V, small step size: 0.1V, large step size: 1V
		58.4V (48V system)	User define: 36.0–62.0V, small step size: 0.1V, large step size: 1V
7★	BCV (Bulk Charging Voltage)	14.4V (12V system)	User define: 9.0–15.5V, small step size: 0.1V, large step size: 1V
		28.8V (24V system)	User define: 18.0–31.0V, small step size: 0.1V, large step size: 1V
		57.6V (48V system)	User define: 36.0–62.0V, small step size: 0.1V, large step size: 1V
8★	FCV (Float Charging Voltage)	13.8V (12V system)	User define: 9.0–15.5V, small step size: 0.1V, large step size: 1V
		27.6V (24V system)	User define: 18.0–31.0V, small step size: 0.1V, large step size: 1V
		55.2V (48V system)	User define: 36.0–62.0V, small step size: 0.1V, large step size: 1V
9★	BVR (Bulk Voltage Recovery Voltage)	13.2V (12V system)	User define: 9.0–15.5V, small step size: 0.1V, large step size: 1V
		26.4V (24V system)	User define: 18.0–31.0V, small step size: 0.1V, large step size: 1V
		52.8V	User define: 36.0–62.0V, small step

		(48V system)	size: 0.1V, large step size: 1V
10★	LVR (Low Voltage Recovery Voltage)	12.6V (12V system)	User define: 9.0–15.5V, small step size: 0.1V, large step size: 1V
		25.2V (24V system)	User define: 18.0–31.0V, small step size: 0.1V, large step size: 1V
		50.4V (48V system)	User define: 36.0–62.0V, small step size: 0.1V, large step size: 1V
11★	UVAR (Undervoltage Alarm Recovery Voltage)	12.2V (12V system)	User define: 9.0–15.5V, small step size: 0.1V, large step size: 1V
		24.4V (24V system)	User define: 18.0–31.0V, small step size: 0.1V, large step size: 1V
		48.8V (48V system)	User define: 36.0–62.0V, small step size: 0.1V, large step size: 1V
12★	UVA (Undervoltage Alarm Voltage)	12.0V (12V system)	User define: 9.0–15.5V, small step size: 0.1V, large step size: 1V
		24.0V (24V system)	User define: 18.0–31.0V, small step size: 0.1V, large step size: 1V
		48.0V (48V system)	User define: 36.0–62.0V, small step size: 0.1V, large step size: 1V
13★	LVD (Low Voltage Disconnect Voltage)	11.1V (12V system)	User define: 9.0–15.5V, small step size: 0.1V, large step size: 1V
		22.2V (24V system)	User define: 18.0–31.0V, small step size: 0.1V, large step size: 1V
		44.4V (48V system)	User define: 36.0–62.0V, small step size: 0.1V, large step size: 1V
14★	ECT (Equalize Charging Time)	120M	User define: 0–180 minutes, small step size: 1 minute, large step size: 10 minutes
15★	BCT (Bulk Charging Time)	120M	User define: 0–180 minutes, small step size: 1 minute, large step size: 10 minutes

16	LBP (Lithium Battery Protection)	OFF	User define: OFF, ON OFF: Disable lithium battery protection ON: Enable lithium battery protection
17	LTCL (Low Temperature Charging Limit)	-5°C	User define: -45°C to 10°C, small step size: 1°C, large step size: 10°C. <b>Note:</b> This parameter goes into effect when "LBP (Lithium Battery Protection)" is set as "ON".
18	MCC (Battery Max Charging Current) <b>Note:</b> This parameter cannot be modified when BMS is connected, the charging is controlled by BMS.	60A	TEP6415/TEP6425: User define: 1–60A, small step size: 1A, large step size: 10A
		75A	TEP7415/TEP7425: User define: 1–75A, small step size: 1A, large step size: 10A
		80A	TEP8415/TEP8425: User define: 1–80A, small step size: 1A, large step size: 10A
		100A	TEP10415/TEP10425: User define: 1–100A, small step size: 1A, large step size: 10A
19	BPRO (BMS Protocol)	32	User define: 1–230, small step size: 1, large step size: 10
20	PCM (PV Connection Mode)	INDE	User define: INDE (Independent Input), CENT (Parallel Input) When two PV arrays are independently input, the value shall be set to "INDE". When two PV arrays are connected in parallel as a single input to the controller (the PV terminals need to be paralleled externally), the value shall be set to "CENT". <b>Note:</b> Product with one PV input is "INDE" by default (this parameter setting is invalid).

21	ADDR (Address)	1	User define: 1–200, small step size: 1, large step size: 10
22	BAUD (Baudrate)	1152	User define: 1152, 96, 24 <b>Note:</b> After setting the parameter, restart the controller for the setting to take effect.
23	TU (Temperature Unit)	°C	User define: °C, °F
24	SCT (Screen Cycle Time)	2S	The switching time of the real-time interface is 0S by default, that is, the real-time interface is not automatically switched. User define: 0–100S, small step size: 1S, large step size: 10S.
25	CPE (Com Port Enable)	ON	User define: OFF, ON When set to “ON”, the communication port is enabled and communication is normal. When set to “OFF”, the external communication is turned off when there is no PV input or charging, otherwise the communication is turned on.
26	CAE (Clear Accumulated Energy)	OFF	User define: OFF, ON When set to “ON”, the accumulated energy is cleared once.
27	PMCC (Parallel Battery Max Charging Current)	1,200A	Limit the total current for parallel charging. If the setting value of this parameter exceeds the maximum charging current of an individual controller times the quantity of parallel controllers, the parameter is invalid and the system will limit the charging according to the maximum charging current of the individual controller. User define: 100–1,200A, small step size: 10A, large step size: 100A

28	RFS (Restore Factory Settings)	OFF	User define: OFF, ON When set to "ON", the factory settings are restored once.
29	AFV (ARM Firmware Version)	--	Read-only. <b>Note:</b> Please refer to the actual display for the specific version.
30	DFV (DSP Firmware Version)	--	Read-only. <b>Note:</b> Please refer to the actual display for the specific version.

★ indicates that this setting is only available and visible when the battery type is set to "USER".

### 3.3.5 Battery voltage control parameters

#### a) Lead-acid battery parameters

The following table shows the voltage control parameters of 12V system (12V battery), voltage control parameters and user-define range of 24V system (24V battery) and 48V system (48V battery) are equal to the parameter values of 12V system times 2 and 4 respectively.

Voltage Control Parameters	Battery Type			
	AGM	GEL	FLD	User Define
Overvoltage Disconnect Voltage	16.0V	16.0V	16.0V	9-17V
Charging Voltage Limit Voltage	15.0V	15.0V	15.0V	9-15.5V
Overvoltage Recovery Voltage	15.0V	15.0V	15.0V	9-15.5V
Equalization Charging Voltage	14.6V	--	14.8V	9-15.5V
Bulk Charging Voltage	14.4V	14.2V	14.6V	9-15.5V
Float Charging Voltage	13.8V	13.8V	13.8V	9-15.5V
Bulk Recovery Voltage	13.2V	13.2V	13.2V	9-15.5V
Low Voltage Recovery Voltage	12.6V	12.6V	12.6V	9-15.5V
Undervoltage Alarm Recovery Voltage	12.2V	12.2V	12.2V	9-15.5V
Undervoltage Alarm Voltage	12.0V	12.0V	12.0V	9-15.5V
Low Voltage Disconnect Voltage	11.1V	11.1V	11.1V	9-15.5V

Discharging Voltage Limit Voltage	10.6V	10.6V	10.6V	9-15.5V
Equalization Charging Time*	120 minutes	--	120 minutes	0-180 minutes
Bulk Charging Time*	120 minutes	120 minutes	120 minutes	10-180 minutes

★When the battery type is changed to lithium battery, the lithium battery protection is automatically enabled, and the default values of "ECT" and "BCT" are changed to 10 minutes.

★When the battery type is changed to "AGM, GEL or FLD", the lithium battery protection is disabled, and the default values of "ECT" and "BCT" are changed to 120 minutes.

★When the battery type is changed to "USER", the values of lithium battery protection, "ECT" and "BCT" remain the same as the previous battery type.

When the default battery type is selected, the battery voltage control parameters cannot be modified. To change these parameters, select the battery type as "USER". Follow the logic below to set the battery type as "USER"

- A. Overvoltage Disconnect Voltage > Charging Voltage Limit Voltage ≥ Equalization Charging Voltage ≥ Bulk Charging Voltage ≥ Float Charging Voltage > Bulk Recovery Voltage;
- B. Overvoltage Disconnect Voltage > Overvoltage Recovery Voltage;
- C. Low Voltage Recovery Voltage > Low Voltage Disconnect Voltage ≥ Discharging Voltage Limit Voltage;
- D. Undervoltage Alarm Recovery Voltage > Undervoltage Alarm Voltage ≥ Discharging Voltage Limit Voltage;
- E. Bulk Recovery Voltage > Low Voltage Recovery Voltage.

#### b) Lithium battery parameters

Voltage Control Parameters \ Battery Type	LFP			
	LFP4S	User Define	LFP8S	User Define
Overvoltage Disconnect Voltage	14.5V	9-17V	29.0V	18-34V
Charging Voltage Limit Voltage	14.3V	9-15.5V	28.6V	18-31V
Overvoltage Recovery Voltage	14.3V	9-15.5V	28.6V	18-31V
Equalization Charging Voltage	14.2V	9-15.5V	28.4V	18-31V
Bulk Charging Voltage	14.2V	9-15.5V	28.4V	18-31V

Float Charging Voltage	13.3V	9-15.5V	26.6V	18-31V
Bulk Recovery Voltage	13.0V	9-15.5V	26.0V	18-31V
Low Voltage Recovery Voltage	12.8V	9-15.5V	25.6V	18-31V
Undervoltage Alarm Recovery Voltage	12.2V	9-15.5V	24.4V	18-31V
Undervoltage Alarm Voltage	12.0V	9-15.5V	24.0V	18-31V
Low Voltage Disconnect Voltage	11.3V	9-15.5V	22.6V	18-31V
Discharging Voltage Limit Voltage	11.0V	9-15.5V	22.0V	18-31V

**Note:** The LFP4S voltage is 12V, the LFP8S voltage is 24V.

Voltage Control Parameters	Battery Type	LFP		
		LFP15S	LFP16S	User Define
Overvoltage Disconnect Voltage		54.7V	58.4V	36-68V
Charging Voltage Limit Voltage		53.6V	57.2V	36-62V
Overvoltage Recovery Voltage		53.6V	57.2V	36-62V
Equalization Charging Voltage		53.3V	56.8V	36-62V
Bulk Charging Voltage		53.3V	56.8V	36-62V
Float Charging Voltage		50.0V	54.0V	36-62V
Bulk Recovery Voltage		49.7V	52.0V	36-62V
Low Voltage Recovery Voltage		48.0V	51.2V	36-62V
Undervoltage Alarm Recovery Voltage		45.7V	48.8V	36-62V
Undervoltage Alarm Voltage		45.0V	48.0V	36-62V
Low Voltage Disconnect Voltage		42.5V	45.2V	36-62V
Discharging Voltage Limit Voltage		41.5V	44.0V	36-62V

**Note:** The voltage of LFP15S and LFP16S is 48V.

Voltage Control Parameters	Battery Type	NCM			
		NCM3S	User Define	NCM6S	NCM7S

Overvoltage Disconnect Voltage	12.9V	9-17V	25.8V	30.1V	18-34V
Charging Voltage Limit Voltage	12.7V	9-15.5V	25.5V	29.7V	18-31V
Overvoltage Recovery Voltage	12.7V	9-15.5V	25.5V	29.7V	18-31V
Equalization Charging Voltage	12.5V	9-15.5V	25.0V	29.1V	18-31V
Bulk Charging Voltage	12.5V	9-15.5V	25.0V	29.1V	18-31V
Float Charging Voltage	12.0V	9-15.5V	24.0V	28.0V	18-31V
Bulk Recovery Voltage	11.7V	9-15.5V	23.4V	27.3V	18-31V
Low Voltage Recovery Voltage	11.1V	9-15.5V	22.2V	25.9V	18-31V
Undervoltage Alarm Recovery Voltage	10.8V	9-15.5V	21.6V	25.2V	18-31V
Undervoltage Alarm Voltage	10.5V	9-15.5V	21.0V	24.5V	18-31V
Low Voltage Disconnect Voltage	9.6V	9-15.5V	19.2V	22.4V	18-31V
Discharging Voltage Limit Voltage	9.3V	9-15.5V	18.6V	21.7V	18-31V

**Note:** The NCM3S voltage is 12V, the voltage of NCM6S and NCM7S is 24V.

Voltage Control Parameters	Battery Type	NCM		
		NCM13S	NCM14S	User Define
Overvoltage Disconnect Voltage		55.9V	60.2V	36-68V
Charging Voltage Limit Voltage		55.2V	59.5V	36-62V
Overvoltage Recovery Voltage		55.2V	59.5V	36-62V
Equalization Charging Voltage		54.2V	58.3V	36-62V
Bulk Charging Voltage		54.2V	58.3V	36-62V
Float Charging Voltage		52.0V	56.0V	36-62V

Bulk Recovery Voltage	50.7V	54.6V	36-62V
Low Voltage Recovery Voltage	48.1V	51.8V	36-62V
Undervoltage Alarm Recovery Voltage	46.8V	50.4V	36-62V
Undervoltage Alarm Voltage	45.5V	49.0V	36-62V
Low Voltage Disconnect Voltage	41.6V	44.8V	36-62V
Discharging Voltage Limit Voltage	40.3V	43.4V	36-62V

**Note:** The voltage of NCM13S and NCM14S is 48V.

When the battery type is set as "USER", follow the logic below to set the voltage parameters of the lithium battery.

- A. Overvoltage Disconnect Voltage > Over Charging Protection Voltage (Protection Circuit Modules(BMS)) plus 0.2V;
- B. Overvoltage Disconnect Voltage > Overvoltage Recovery Voltage = Charging Voltage Limit Voltage ≥ Equalization Charging Voltage = Bulk Charging Voltage ≥ Float Charging Voltage > Bulk Recovery Voltage;
- C. Low Voltage Recovery Voltage > Low Voltage Disconnect Voltage ≥ Discharging Voltage Limit Voltage;
- D. Undervoltage Alarm Recovery Voltage > Undervoltage Alarm Voltage ≥ Discharging Voltage Limit Voltage;
- E. Bulk Recovery Voltage > Low Voltage Recovery Voltage;
- F. Low Voltage Disconnect Voltage ≥ Over Discharging Protection Voltage (BMS) plus 0.2V.

#### NOTICE

- The lithium battery parameters must be set according to its BMS voltage parameters.
- It is required that the BMS accuracy of the lithium battery installed in the system is less than or equal to 0.2V, if it is higher than 0.2V, we shall not be liable for any system error.

### 3.3.6 Control strategy under lithium battery protocol

When the BMS is connected correctly, the BPRO (BMS protocol) is set correctly, and "UBS (Use BMS Settings)" is set to "ON", the system follows the following control strategies:

No.	Status/Condition	Control strategy
1	Battery forced charge request appears.	Forced charge the battery with the charging current value provided by the BMS.

2	The BMS sends an exit forced charge command.	Exit the battery forced charge mode and resumes normal operating mode.
3	Read the charging voltage upper limit and the discharging voltage lower limit from the BMS*	Each control voltage is converted according to the table "Conversion Relationship of Each Control Voltage", and the system is charged according to the converted voltage value, and the LCD meter displays the converted voltage value. <b>Note:</b> If the BMS communication is normal but charging voltage upper limit and the discharging voltage lower limit cannot be read, the system will be charged according to the value set by the customer.
4	Read the charging limit current from the BMS.	Limit the charging current as the read charging current limit value.
5	Turn off charging meter and display BCF.	BMS uploads the battery full charge status (Battery is fully charged).
6	BMS voltage and current limiting parameters are taking effect.	The controller limits charging according to the maximum charging current value uploaded by BMS and the meter displays BLC.

★For the maximum charging voltage and the minimum discharging voltage of the lithium battery, please refer to its specification sheet.

- Conversion Relationship of Each Control Voltage

No.	LCD	Control Voltage	Converted Voltage
1	OVD	Overvoltage Disconnect Voltage	Charging Voltage Upper Limit + 0.3 × Level
2	CLV	Charging Limit Voltage	Charging Voltage Upper Limit (namely, the Battery Pack Overvoltage Alarm Voltage)
3	OVR	Overvoltage Recovery Voltage	Charging Voltage Upper Limit
4	ECV	Equalization Charging Voltage	Charging Voltage Upper Limit - 0.1 × Level
5	BCV	Bulk Charging Voltage	Charging limit voltage - 0.1 × Level
6	FCV	Float Charging Voltage	Charging limit voltage - 0.1 × Level
7	BVR	Bulk Recovery Voltage	Charging Voltage Upper Limit - 0.8 × Level

8	LVR	Low Voltage Recovery Voltage	Discharging Voltage Lower Limit + 0.7 × Level
9	UVR	Undervoltage Alarm Recovery Voltage	Discharging Voltage Lower Limit + 0.7 × Level
10	UVW	Undervoltage Alarm Voltage	Discharging Voltage Lower Limit + +0.4 × Level
11	LVD	Low Voltage Disconnect Voltage	Discharging limit voltage (namely, the battery pack Undervoltage Alarm Voltage)
12	DLV	Discharging Limit Voltage	Discharging limit voltage - 0.7 × Level

### 3.3.7 Setting parameters remotely

#### a) Setting the “USER” voltage parameters by PC software

Connect the COM port of the controller to the PC USB port by the USB to RS485 communication cable (optional accessory) to enable setting custom battery type parameters through the PC software.

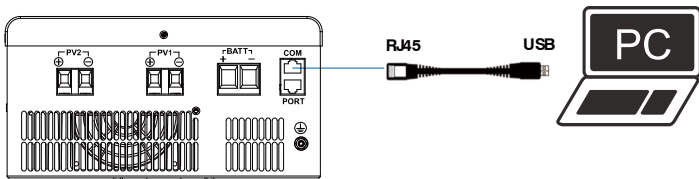

#### b) Setting by APP

- Connecting the external WiFi module

Connect the WiFi module (optional accessory) to the COM port of the controller, and set the “USER” voltage parameters on the APP through the WiFi signal. For specific setting methods, please refer to the cloud APP manual.

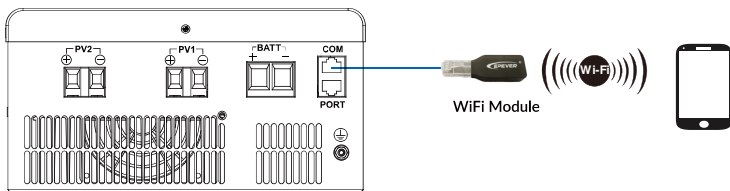

- Connecting the external Bluetooth module

---

Connect the Bluetooth module (optional accessory) to the COM port of the controller, and set the "USER" voltage parameters on the APP through the Bluetooth signal. For specific setting methods, please refer to the cloud APP manual.

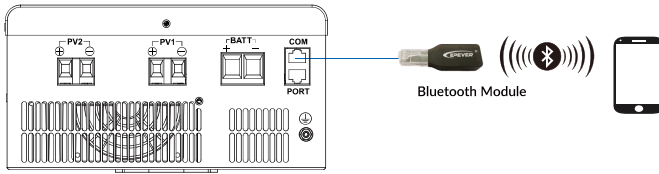

---

## 4 Maintenance

To maintain long-term working performance, it is recommended to have the following items inspected twice a year.

- Ensure proper ventilation/heat dissipation around the controller; clean dirt or debris from the heat sink.
- Check whether the insulation of exposed cables have been damaged by sunlight, friction with objects, insects or rodents, etc. Repair or replace the cables if necessary.
- Check whether the indicator and display are consistent with the actual operation of the equipment, and note fault/error displays and take corrective actions if needed.
- Inspect terminal blocks for corrosion, insulation damage or high-temperature burn marks; check that terminal screws are tight.
- If the lightning arrester has failed, replace it in time to avoid lightning strikes' damage to the controller or even other equipment.



**DANGER**

- Electric shock hazard! Ensure that the power supply of the controller is disconnected when performing the above operations!

## 5 Protections

Protections	Description
PV current/power-limiting	When the actual charging current/power of the PV array exceeds its rated current/power, it will charge the battery as per the rated current/power.
PV short circuit	When PV is not charging the battery and is short-circuit, the controller will not be damaged. <b>Note:</b> It is forbidden to short-circuit the PV array during charging. Otherwise, the controller may be damaged.
PV reverse polarity	When the PV array polarity is reversed, the controller will not be damaged and will resume normal operation after correction. <b>Note:</b> When the actual operating power of the PV array exceeds 1.5 times the controller's rated charging power during reverse connection, the controller will be damaged. For models with an open-circuit voltage of 150V (when the battery is connected correctly), normal protection is ensured, while for the TEP**25 model, normal protection works only if the PV array's open-circuit voltage is below 200V, and exceeding 200V will damage the controller.
Night reverse charging	This function prevents the battery from discharging to PV modules at night (when battery voltage exceeds PV module voltage).
Battery overvoltage	When the battery voltage is higher than the "OVD (Overvoltage Disconnect Voltage)", the controller will automatically stop charging the battery to protect the battery from over charging.
Battery over discharge	When the battery voltage is lower than the "LVD (Low Voltage Disconnect Voltage)", the over discharge alarm will occur on the LCD.
Battery over temperature	The controller detects the battery temperature by an external temperature sensor. The battery stops working when its temperature goes higher than 65°C and resumes operation when its temperature is below 55°C.
Lithium battery low temperature charging	When the temperature detected by the optional temperature sensor is lower than "LTCL (Low Temperature Charging Limit)", the controller stops charging automatically. When the detected temperature is higher than the "LTCL", the controller resumes charging automatically. (The "LTCL" is 0°C by default and can be set within the range from -40°C to 10°C. For detailed settings of relevant parameters, please refer to Subsection <a href="#">3.3.4 Parameters list</a> .)

Controller over temperature*	The controller detects its internal temperature by the internal temperature sensor. The controller stops operating when its internal temperature is higher than 85°C, and resumes operating when its internal temperature is below 75°C.
TVS high voltage surge	The internal circuit of this controller is designed with Transient Voltage Suppressors (TVS), which can only protect against high-voltage surge pulses with less energy. If the controller is used in an area with frequent lightning strikes, it is recommended to install an external lightning arrester.

★ When the control's internal temperature is 81°C, the charging power reduction mode is turned on. For every 1°C increase in temperature, the charging power is reduced by 5%, 10%, 20%, and 40% respectively. When the temperature is higher than 85°C, the charging is stopped. While the internal temperature is not more than 75°C, the controller will resume charging as per the rated charging power. For example, TEP10425 system:

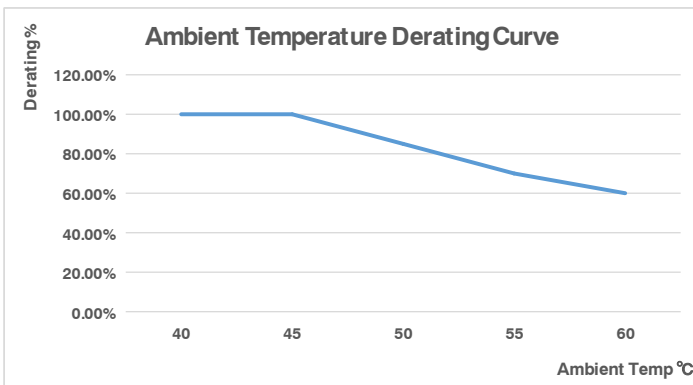
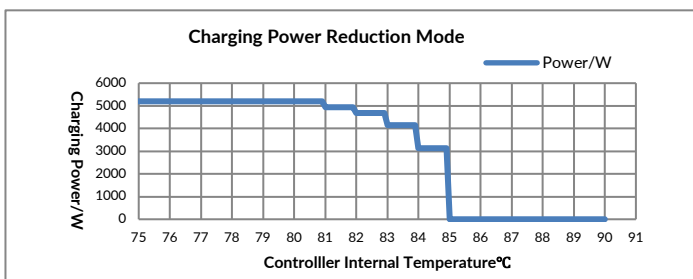

## 6 Troubleshooting

Status	Error Code	Possible Reasons	Troubleshooting
PV indicator is fast flashing green.	POV	PV Overvoltage	Check whether the connected PV open circuit voltage is higher than the PV maximum open circuit voltage, and the alarm is cleared when the PV open circuit voltage is lower than the PV maximum open circuit voltage minus 5V.
	PME	PV Work Mode Error	Check whether the PV connection method is consistent with the parameter settings of "PCM (PV Connection Mode)".
	RPP	PV Reverse Polarity Protection	Check whether the PV is connected to the battery correctly.
	PPL	PV Power Low	Wait until there is sufficient sunlight to check whether the fault is cleared.
BATT indicator is solid orange.	BUV	Battery Undervoltage Alarm (including battery pack Undervoltage alarm)	Disconnect the loads connection, and check whether the battery voltage is too low. After the battery is charged and its voltage is restored above "UVAR (Undervoltage Alarm Recovery Voltage)", it will automatically resume normal operation, or recharge the battery with other methods.
	CUV	Cell Undervoltage Protection	Check the BMS communication status or BMS parameters settings.
BATT indicator is solid red.	BOD	Battery Over Discharging Protection	Disconnect the loads connected to the battery, and check whether the battery voltage is too low. After the battery is charged and its voltage is restored above "LVR (Low Voltage Recovery Voltage)", it will automatically resume normal operation, or use other methods to recharge the battery.

BATT indicator is fast flashing red.	BOF	BMS Other Fault	Check whether the battery BMS connection is normal.
	BSF	BMS Sensor Fault	
	LBVE	Lithium Battery Rated Voltage Identification Error	Check whether the lithium battery is connected to the controller correctly or the voltage uploaded by BMS is consistent with the voltage at the controller battery terminals.
BATT indicator is fast flashing green.	BOV	Battery Overvoltage Protection	Disconnect all charging and measure whether the battery voltage is too high, and check whether the voltage of the connected battery matches the rated voltage level of the controller, or check whether the setting value of the battery "OVD (Overvoltage Disconnect Voltage)" is inconsistent with the battery specifications. After the battery voltage drops below the set value of "OVR (Overvoltage Recovery Voltage)", the alarm will automatically be cleared.
	COV	Cell Overvoltage Protection	Check the BMS communication status or BMS parameters settings.
BATT indicator is slowly flashing red.	BOT	Battery Over Temperature	Ensure the battery is installed in a cool and well-ventilated place, check that the battery actual charging and discharging current does not exceed the set values of "Battery Max Charging Current". (If BMS is connected, "MCC" is the read value from the BMS, which cannot be set. When the battery temperature drops below the "BATT OTPR (Battery Over Temperature Recovery)", the controller resumes normal charging control.

	BLT	Battery Low Temperature	Check whether the ambient temperature is lower than the "LTCL (Low Temperature Charging Limit)" and "LTDL (Low Temperature Discharging Limit)", when the ambient temperature is higher than the "LTCL + 2°C" or "LTDL + 2°C", the battery resumes normal operating.
	COT	Cell Over Temperature Protection	Check the BMS communication status or BMS parameters settings.
	CLT	Cell Low Temperature Protection	
	BCP	BMS Charging Protection	
	BDP	BMS Discharging Protection	
BATT indicator is slowly flashing green.	SLBP	SOC Low Battery Protection	Charge the battery to LBAR (Low Battery Alarm Recovery SOC)
--	BOCD	BMS Over Current Discharging Alarm	Check the BMS communication status or BMS parameters settings.
	BOCC	BMS Over Current Charging Alarm	
	BLC	BMS voltage and current limiting parameters are taking effect	BMS is normal and no troubleshooting is required.
	PIDR	Parallel ID Repetition	Check whether the IDs of parallel equipment is repeated.
PV indicator is fast flashing green. BATT indicator is fast flashing orange.	DOT	Device Over Temperature	Ensure the controller is installed in a cool and well-ventilated place, When the controller temperature drops below the "DOT (Device Over Temperature)", the controller resumes normal charging control.
	DCF	DSP Communication Fault	Turn off the controller first, wait for 5 minutes, then turn it on again to check whether it returns to normal. If

			this error persists, please contact our technical support.
--	--	--	------------------------------------------------------------

## 7 Technical Specifications

Model	TEP6415	TEP7415	TEP8415	TEP10415
<b>PV Input (DC)</b>				
Maximum Open-circuit Voltage	150V (@lowest temperature); 135V (@25°C)			
MPPT Voltage Range	(Battery voltage plus 2V, and > 20V) to 108V (@25°C)			
Number of MPPTs	1			2
<b>Battery</b>				
Battery Type	AGM (Default)/GEL/FLD/User			
Lithium Battery Type	LFP/NCM/User			
Rated Voltage	12/24/48VDC or Auto			
Rated Charging Current	60A	75A	80A	100A
Rated Charging Power	780W/ 1,560W/ 3,120W	975W/ 1,950W/ 3900W	1,040W/ 2,080W/ 4,160W	1,300W/ 2,600W/ 5,200W
Temperature Compensation Coefficient	-3mV/°C/2V (Default)			
<b>Controller</b>				
Output Voltage Range	8–62V			
Static Loss (Enabled Communication)	98mA/12V; 60mA/24V; 46mA/48V			
Static Loss (Disabled Communication)	48mA/12V; 25mA/24V; 14mA/48V			
Grounding Type	Common negative grounding			

Communication Method	5VDC/200mA (RJ45)			
<b>Efficiency</b>				
Tracking Efficiency	≥ 99.5%			
Maximum Conversion Efficiency	98.3%	98.2%	98.3%	98.4%
<b>Environmental Parameters</b>				
Operating Temperature	-25°C to +60°C (> 45°C derating)			
LCD Operating Temperature	-20°C to +70°C			
Storage Temperature	-30°C to +70°C			
Relative Humidity	5%–95% (N.C.)			
Altitude	< 5,000m (> 2,000m derating)			
Ingress Protection	IP20			
Pollution Degree	II			
<b>Mechanical Parameters</b>				
Dimensions (L × W × H)	200mm × 357mm × 90 mm			231mm × 298mm × 119mm
Mounting Hole Size	Φ8mm			
Weight	4.47kg	4.58kg	4.51kg	5.2kg
<b>Others</b>				
Certifications	EN/IEC61000-6-2; EN/IEC61000-6-4; EN/IEC62109-1; IEC62321			

<b>Model</b>	<b>TEP6425</b>	
<b>PV Input (DC)</b>		
Maximum Open-circuit Voltage	250V (@ lowest temperature); 225V (@ 25°C)	
MPPT Voltage Range	(Battery voltage plus 2V, and > 20V) to 180V (@ 25°C)	
Number of MPPTs	1	2
<b>Battery</b>		
Battery Type	AGM (Default)/GEL/FLD/User	
Lithium Battery Type	LFP/NCM/User	
Rated Voltage	12/24/48VDC or Auto	
Rated Charging Current	60A	
Rated Charging Power	780W/ 1,560W/ 3,120W	
Temperature Compensation Coefficient	-3mV/°C/2V (Default)	
<b>Controller</b>		
Output Voltage Range	8-62V	
Static Loss (Enabled Communication)	98mA/12V; 60mA/24V; 46mA/48V	
Static Loss (Disabled Communication)	48mA/12V; 25mA/24V; 14mA/48V	
Grounding Type	Common negative grounding	
Communication Method	5VDC/200mA (RJ45)	

Efficiency	
Tracking Efficiency	≥ 99.5%
Maximum Conversion Efficiency	98.5%
Environmental Parameters	
Operating Temperature	-25°C to +60°C (> 45°C derating)
LCD Operating Temperature	-20°C to +70°C
Storage Temperature	-30°C to +70°C
Relative Humidity	5%–95% (N.C.)
Altitude	< 5,000m (> 2,000m derating)
Ingress Protection	IP20
Pollution Degree	II
Mechanical Parameters	
Dimensions (L × W × H)	200mm × 357mm × 90 mm
Mounting Hole Size	Φ8mm
Weight	4.47kg
Others	
Certifications	EN/IEC61000-6-2; EN/IEC61000-6-4; EN/IEC62109-1; IEC62321

## 8 Appendix Abbreviation Index

- LCD Parameter Setting Abbreviations

Abbreviations	Full Name
BT	Battery Type
DFV	DSP Firmware Version
AFV	ARM Firmware Version
PMCC	Parallel Maximum Charging Current
CAE	Clear Accumulated Energy
CPE	Com Port Enable
SCT	Screen Cycle Time
TU	Temperature Unit
BAUD	Baud rate
ADDR	Address
PCM	PV Connection Mode
BPRO	BMS Protocol
MCC	Battery Max Charging Current
LBP	Lithium Battery Protection
LTCL	Low Temperature Charging Limit
BCT	Bulk Charging Time
ECT	Equalization Charging Time
LVD	Low Voltage Disconnect Voltage
UVA	Undervoltage Alarm Voltage
UVAR	Undervoltage Alarm Recovery Voltage
LVR	Low Voltage Recovery Voltage
BVR	Bulk Recovery Voltage
FCV	Float Charging Voltage

BCV	Bulk Charging Voltage
ECV	Equalization Charging Voltage
OVR	Overvoltage Recovery Voltage
OVD	Overvoltage Disconnect Voltage
RVL	Rated Voltage Level
BC	Battery Capacity
RFS	Restore Factory Settings

- **Error Codes Abbreviations**

Abbreviations	Full Name
POV	PV Overvoltage
PME	PV Work Mode Error
RPP	PV Reverse Polarity Protection
PPL	PV Power Low
BUV	Battery Undervoltage Alarm (including battery pack Undervoltage alarm)
BOV	Battery Overvoltage Protection
BOD	Battery Over Discharging Protection
BOT	Battery Over Temperature
BLT	Battery Low Temperature
COV	Cell Overvoltage Protection
CUV	Cell Undervoltage Protection
CLT	Cell Low Temperature Protection
COT	Cell Over Temperature Protection
BOF	BMS Other Fault
BSF	BMS Sensor Fault
BCP	Charging Protection(BMS)
BDP	Discharging Protection(BMS)

SLBP	Low Battery Protection(SOC)
BOCD	Over Current Discharging Alarm(BMS)
BOCC	Over Current Charging Alarm(BMS)
BLC	Battery Limit Charging
DOT	Device Over Temperature
DCF	DSP Communication Fault
LBVE	Lithium Battery Rated Voltage Identification Error Alarm

## 9 Warranty Information

Our product is guaranteed to be free from manufacturing defects for a period of 12 Months.

If your product becomes defective during this period, Electus Distribution will repair, replace, or refund where a product is faulty; or not fit for intended purpose.

This warranty will not cover modified product; misuse or abuse of the product contrary to user instructions or packaging label; change of mind and normal wear and tear.

Our goods come with guarantees that cannot be excluded under the Australian Consumer Law.

You are entitled to a replacement or refund for a major failure and for compensation for any other reasonably foreseeable loss or damage. You are also entitled to have the goods repaired or replaced if the goods fail to be of acceptable quality and failure does not amount to a major failure.

To claim warranty, please contact the place of purchase. You will need to show receipt or other proof of purchase. Additional information may be required to process your claim.

Any expenses relating to the return of your product to the store will normally have to be paid by you.

The benefits to the customer given by this warranty are in addition to other rights and remedies of the Australian Consumer Law in relation to the goods or services to which this warranty relates.

This warranty is provided by:

Electus Distribution

Address 46 Eastern Creek Drive, Eastern Creek NSW 2766

Ph. 1300 738 555