

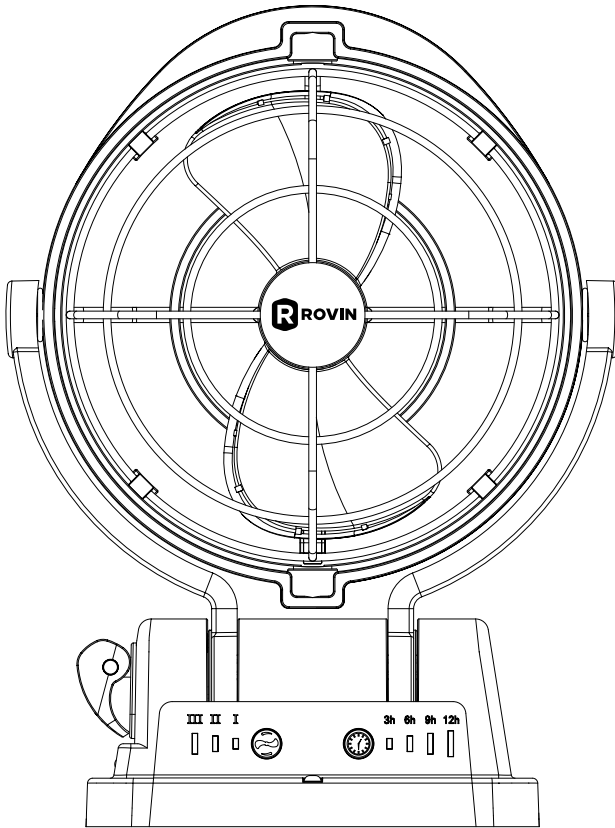

GH1008

RV & Caravan Interior Fan



INSTRUCTION MANUAL

BOX CONTENTS

- 1 x Fan Unit
- 1 x Remote Control
- 1 x User Manual
- 1 x Mounting Kit, including:
 - 1 x Mounting Bracket
 - 1 x Power Cable Wiring
 - 2 x Screws (M4)
 - 4 x Locking Nuts (M4)
 - 2 x Locking Washers
 - 1 x Double Sided Tape

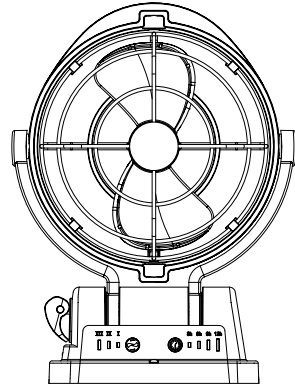

Fan Unit

Ensure all components are present before installation.

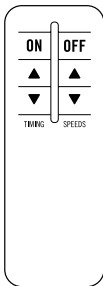

Remote Control

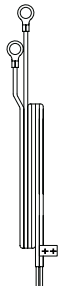

Power Cable
Wiring

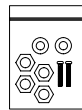

Screws, Nuts
& Washers



Double-Sided
Tape

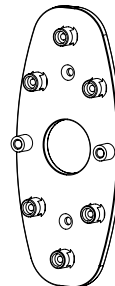

Mounting
Bracket

INSTALLATION GUIDE

Step 1:

On the base of the fan unit, connect the red power cable wire to the positive base screw. Repeat this with the black wire to the negative base screw.

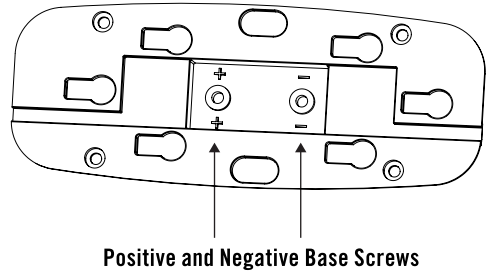

Step 2:

Place the provided nuts and locking washers orderly onto the screw to secure the cables in place.

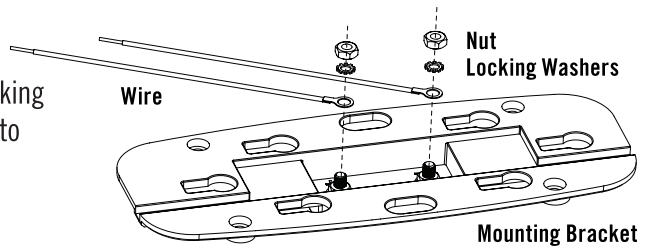

Step 3:

Option A: Thread the two power cable wires through the middle hole on the base plate.

Option B: Place the two wires along the horizontal notches to allow the power cable wires to lay flush with the unit.

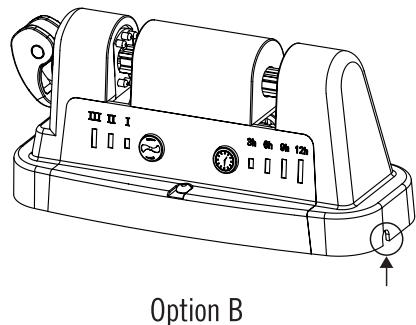
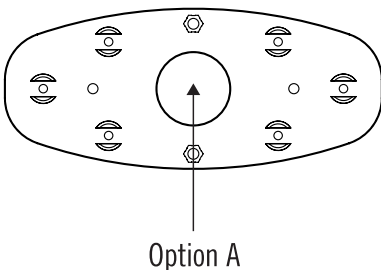

Step 4:

Insert the provided nut in the hexagonal groove on the mounting bracket.

Locate a solid wall or wall frame in our RV or caravan. Fix the mounting bracket onto the wall with the provided double sided tape to ensure correct placement before screwing into the wall. Once the mounting bracket is in place, use screws to install the mounting bracket. (Screws not included)

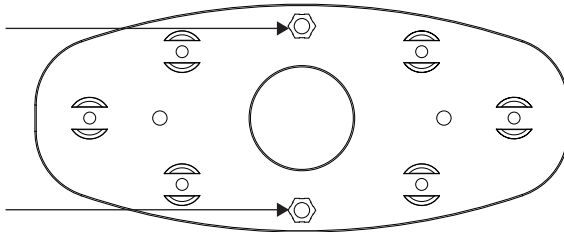

Step 5:

Hang the fan by aligning the knobs on the mounting bracket with the holes in the base of the fan and slide fan onto the mounting bracket.

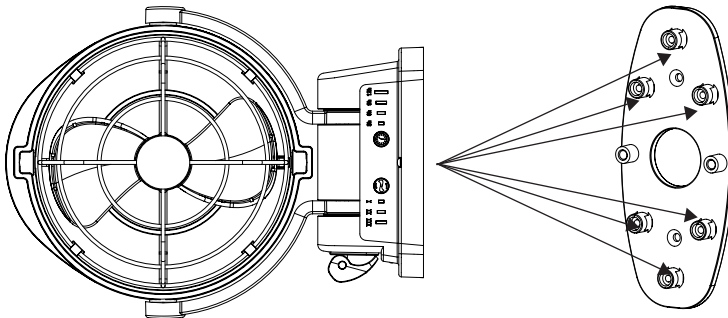

Step 6:

Secure the fan to the mounting bracket using the supplied screws.

Step 7:

Connect your fan to the desired power source using the power cable wiring.

OPERATING GUIDE

Before use, ensure the blades of the fan are free from obstruction.

LOCKING MECHANISM

Lock the fan into place using the locking mechanism on the fan arm. The mechanism is engaged when the arm is facing downward. Move the arm upward to unlock the fan position.

BUTTON LIGHTING

When any button is pressed, the blue lighting within the fan unit will illuminate behind the selected setting.

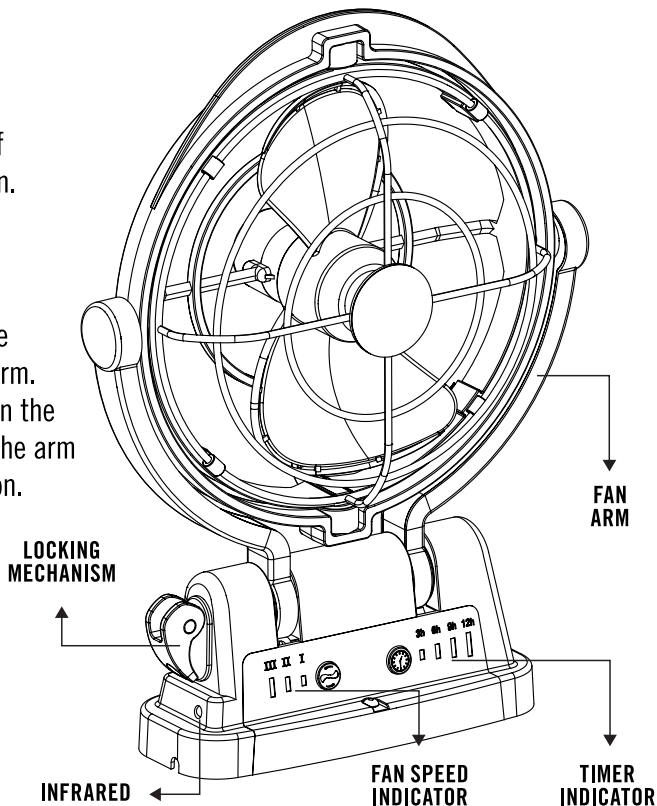

FAN SPEED

Press the speed button once for low speed, twice for medium and three times for high. Press the speed button four times to power off.

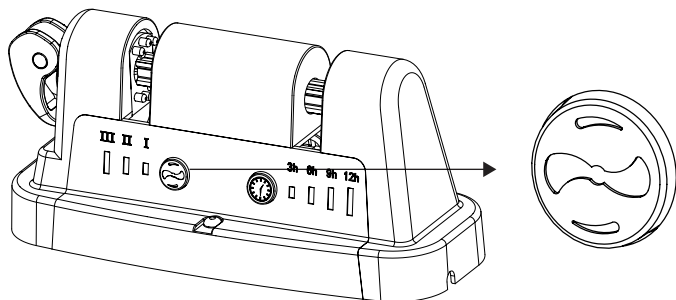

FAN TIMER

Ensure the fan is powered on and running before pressing the timer button.

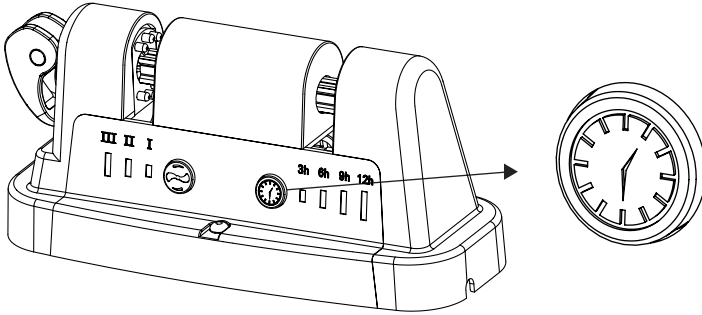

REMOTE CONTROL

1. Ensure the fan is connected to the power supply.
2. Press the “ON” button to start the fan.
3. Use the upward speed button to increase the speed and the downward speed button to decrease the speed.
4. The fan will default to the lowest fan speed upon start up.
5. Press the upward timer button to activate the timer, press again to increase time. Press the downward timer button to decrease the timer length.
6. Press the “OFF” button to turn off the fan.

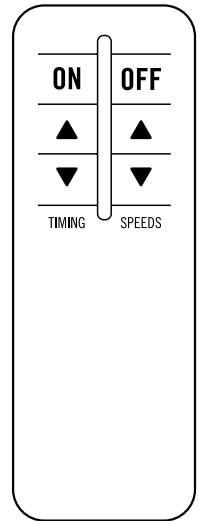

BATTERY REPLACEMENT FOR REMOTE CONTROL

1. Slide the battery cover off the back of the remote control.
2. Remove the old batteries and insert new batteries, ensuring the polarity matches the markings inside the compartment. Batteries required: 2 x AAA. (Batteries not included)
3. Close the battery cover.

TROUBLESHOOTING

ISSUE	SOLUTION
Fan does not turn on	Check the power connection and ensure the power source is 12/24V DC.
Fan speed does not change	Ensure the remote control has functioning batteries and is pointed directly at the fan's sensor.
Unusual noise during operation	Check for obstructions in the fan blades and ensure the fan is securely mounted.
Timer function not working	Ensure the fan is powered on and running before setting the timer. Reset the timer by pressing the same button again.

SAFETY PRECAUTIONS

- Do not modify or disassemble the fan, as this may result in damage or injury.
- Avoid placing the fan near heat sources or flammable materials.
- Ensure proper ventilation around the fan during operation to prevent overheating.

CARE & MAINTENANCE

- Ensure the fan is powered off before cleaning.
- Using a damp cloth, wipe the fan blades to remove any dust build up.
- Do not use harsh chemicals to clean the unit.
- Ensure no moisture comes into contact with the circuit board and electronics.

SPECIFICATIONS

FAN SPEED	CURRENT DRAW AMPS		RPM
	12 Volt	24 Volt	
Low	0.15	0.10	1200±100
Medium	0.22	0.15	1500±100
High	0.31	0.23	1800±100

Maximum Airflow: 140 CFM (Cubic Feet Per Minute)

WARNINGS

- The fan must only be powered by a 12/24V DC power supply.
- The fan must not be connected to a power source supply higher than 24V or to AC.
- This fan is designed for indoor use only.
- Do not place objects near fan or its blades.
- Do not operate fan in a damp environment.
- Do not allow water droplets to enter the fan.
- Keep the fan away from children.
- Avoid using harsh chemicals to clean the fan.
- The fan is equipped with a circuit board that provides protection against both high and low voltage. If the voltage drops below 9V or exceeds 29V, the fan will automatically stop operating to prevent damage.

WARRANTY INFORMATION

Our product is guaranteed to be free from manufacturing defects for a period of 12 Months.

If your product becomes defective during this period, Electus Distribution will repair, replace, or refund where a product is faulty; or not fit for intended purpose.

This warranty will not cover modified product; misuse or abuse of the product contrary to user instructions or packaging label; change of mind and normal wear and tear.

Our goods come with guarantees that cannot be excluded under the Australian Consumer Law. You are entitled to a replacement or refund for a major failure and for compensation for any other reasonably foreseeable loss or damage. You are also entitled to have the goods repaired or replaced if the goods fail to be of acceptable quality and failure does not amount to a major failure.

To claim warranty, please contact the place of purchase. You will need to show receipt or other proof of purchase. Additional information may be required to process your claim.

Any expenses relating to the return of your product to the store will normally have to be paid by you.

The benefits to the customer given by this warranty are in addition to other rights and remedies of the Australian Consumer Law in relation to the goods or services to which this warranty relates.

This warranty is provided by:

Electus Distribution

Address 46 Eastern Creek Drive, Eastern Creek NSW 2766

Ph. 1300 738 555